

1

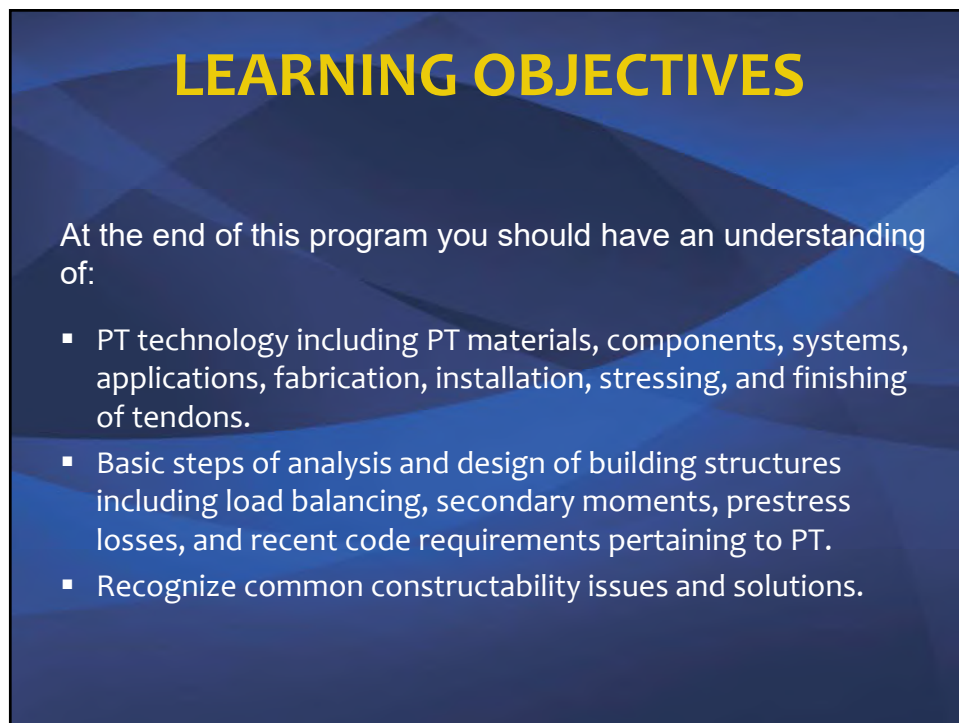

2

Post-Tensioning Institute (PTI)

- A non-profit organization for the advancement of prestressed post-tensioned concrete
- Established in 1976

Activities

- Technical Committees
- Industry Standards and other technical documents
- Dissemination of technical information
- Plant Certification
- Field Personnel Certification
- PT Convention and Technical Sessions
- Research projects and scholarships

3

INTRODUCTION

- Prestressed Concrete
- Advantages of Post-Tensioning (PT)
- Bonded and Unbonded PT
- PT Applications
- Two-Way Slabs
- One-Way Systems

4

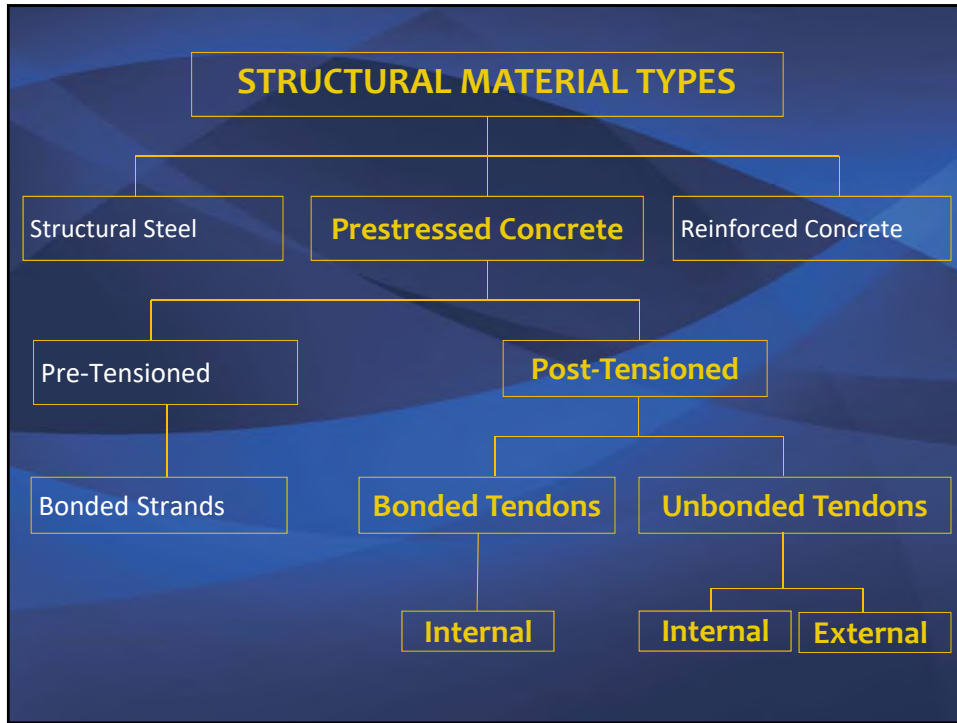

5

- **Prestressing:** Concrete pre-compressed before loading in bending (flexural tension)

METHODS OF PRESTRESSING

1. **Pre-Tensioning:** Steel tensioned **before** concrete is placed (typically precast)
2. **Post-Tensioning:** Steel tensioned **after** concrete is placed and hardened (typically cast-in-place)

Prestressing is **ACTIVE** – can prevent cracks from forming

6

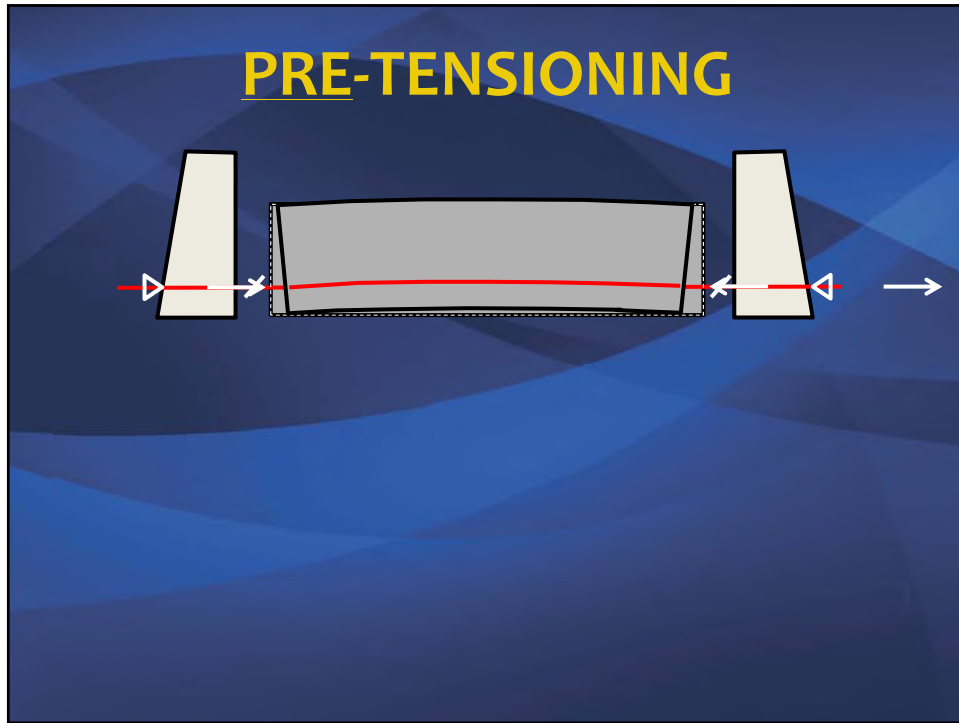

7

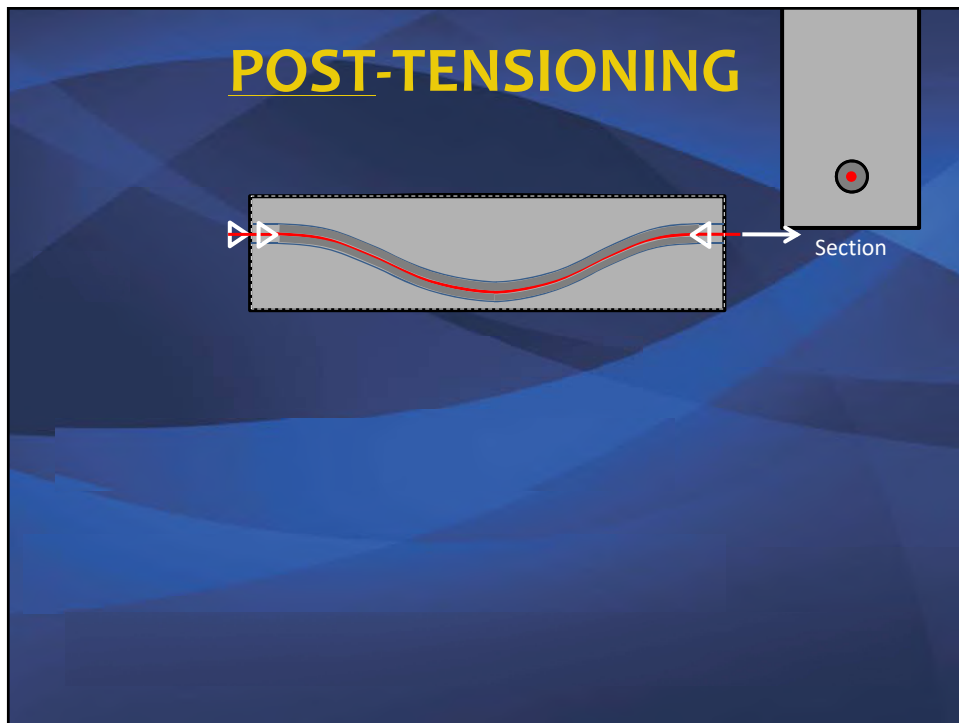

8

Force Transfer by Steel-Concrete bond

Pre-Tensioning

Force Transfer at end anchor

Post-Tensioning

Strain Compatibility and Force Equilibrium:

Steel held at length longer than it originally was: **Tension**

Concrete compressed shorter than it originally was: **Compression**

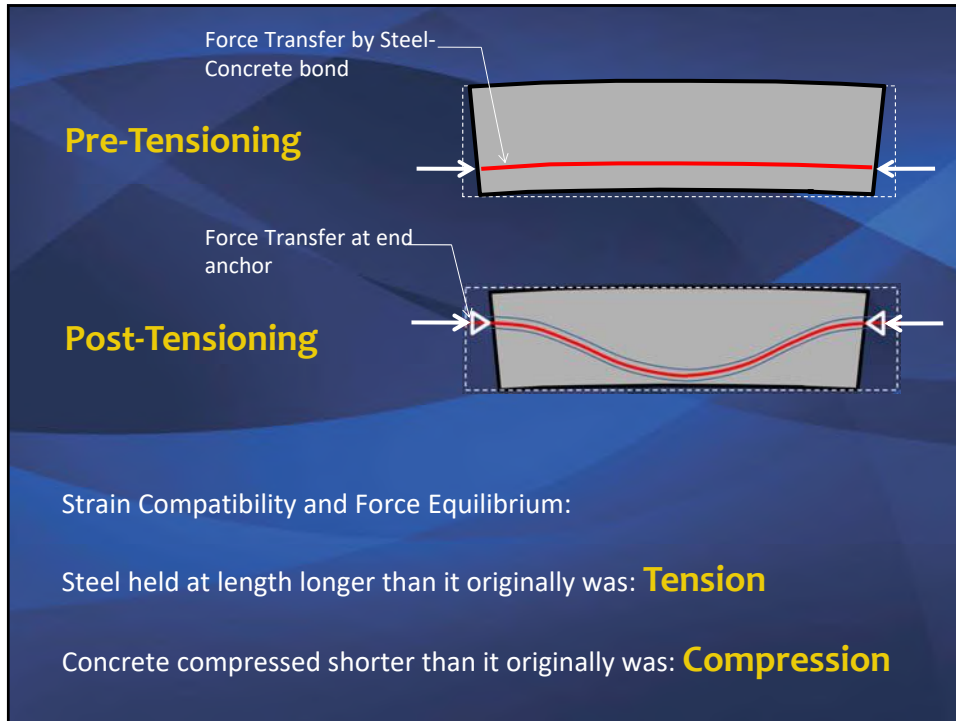

9

REINFORCED CONCRETE

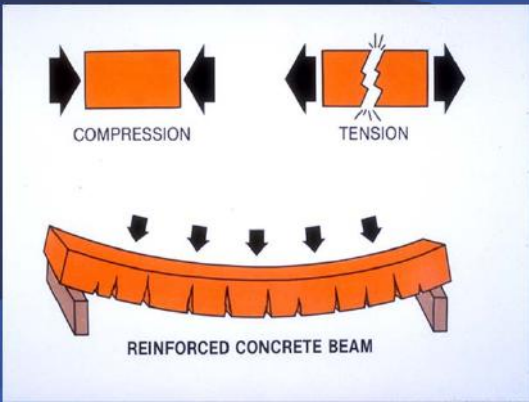

COMPRESSION

TENSION

REINFORCED CONCRETE BEAM

Reinforcement is **PASSIVE**

Nonprestressed reinforcement is fully engaged only after the concrete cracks. It does not prevent cracking but it keeps cracks smaller and distributed.

10

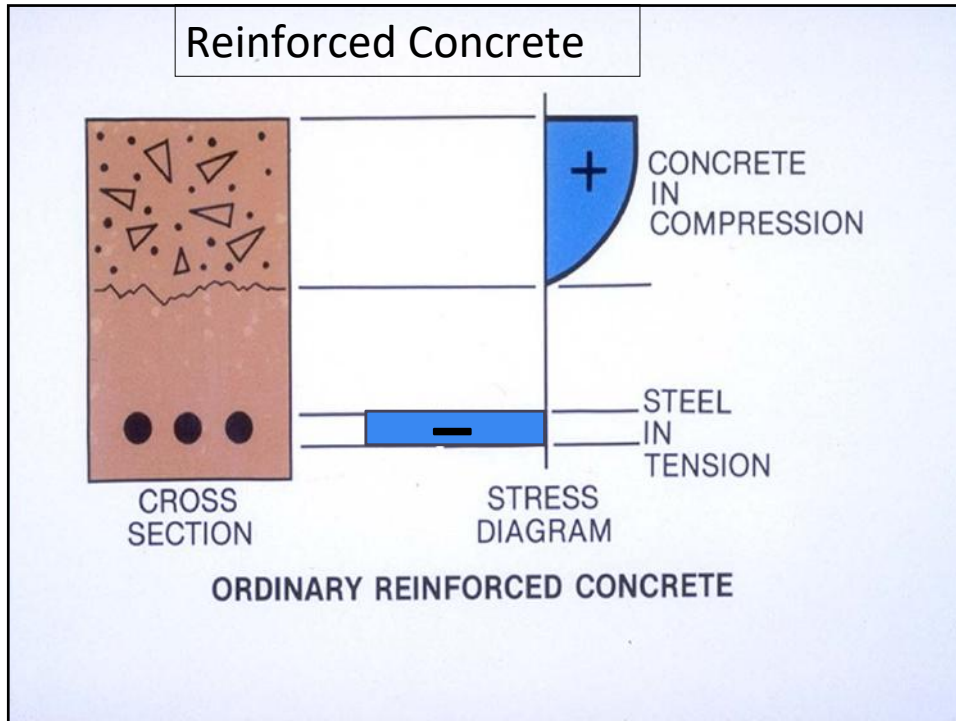

11

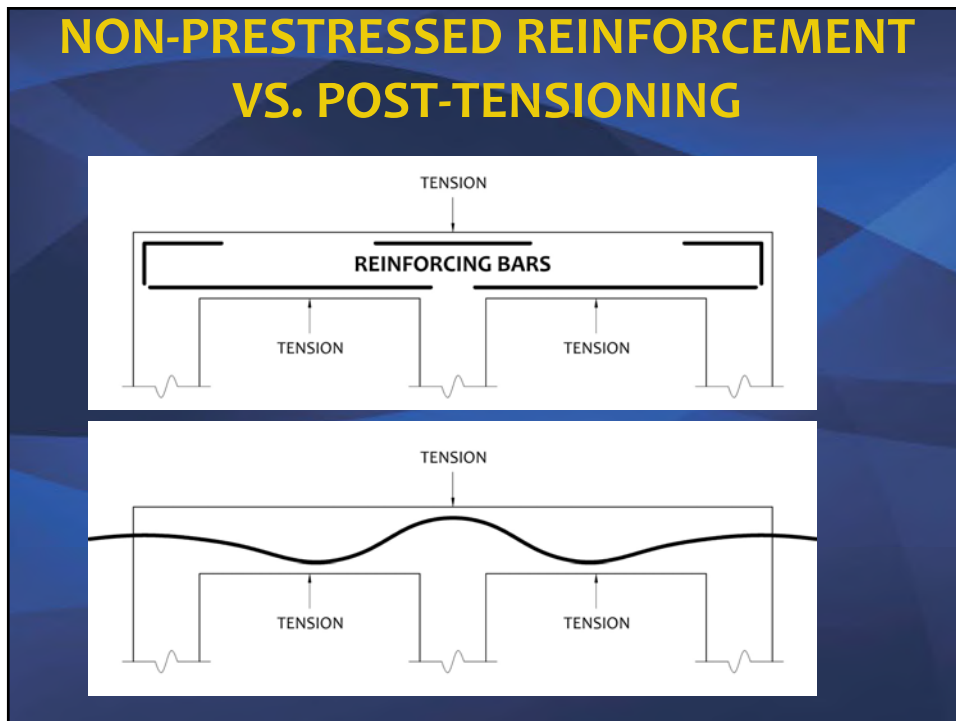

12

SIMPLE PRESTRESSED BEAM

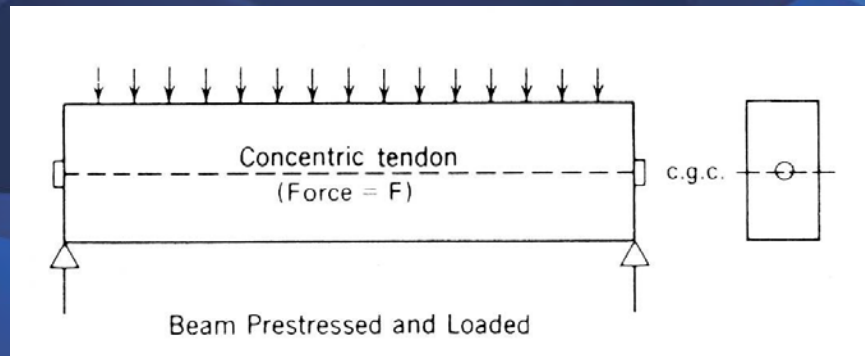

13

SIMPLE PRESTRESSED BEAM

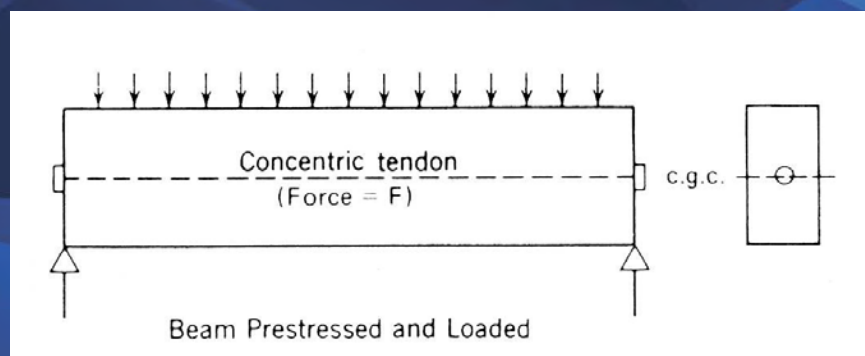

14

BEAM WITH PARABOLIC TENDON

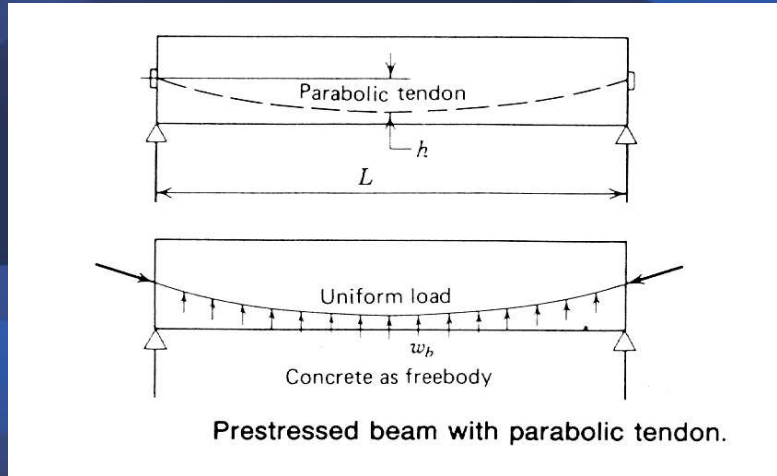

15

BEAM WITH HARPED TENDON

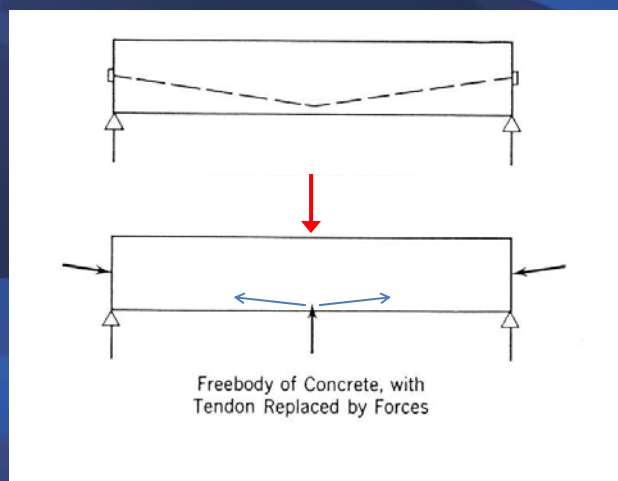

16

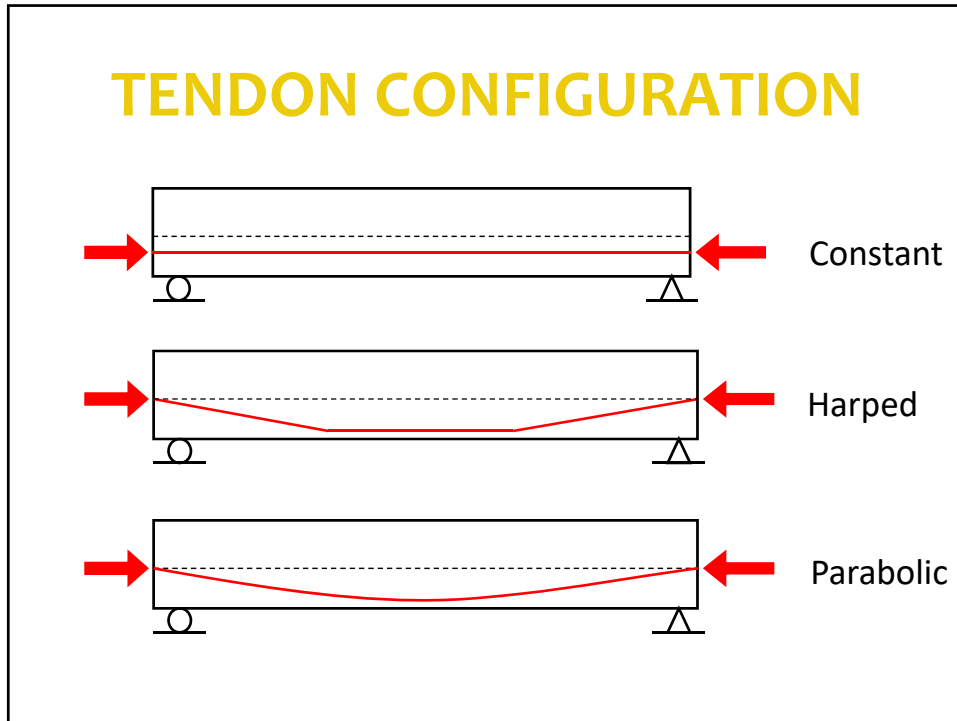

17

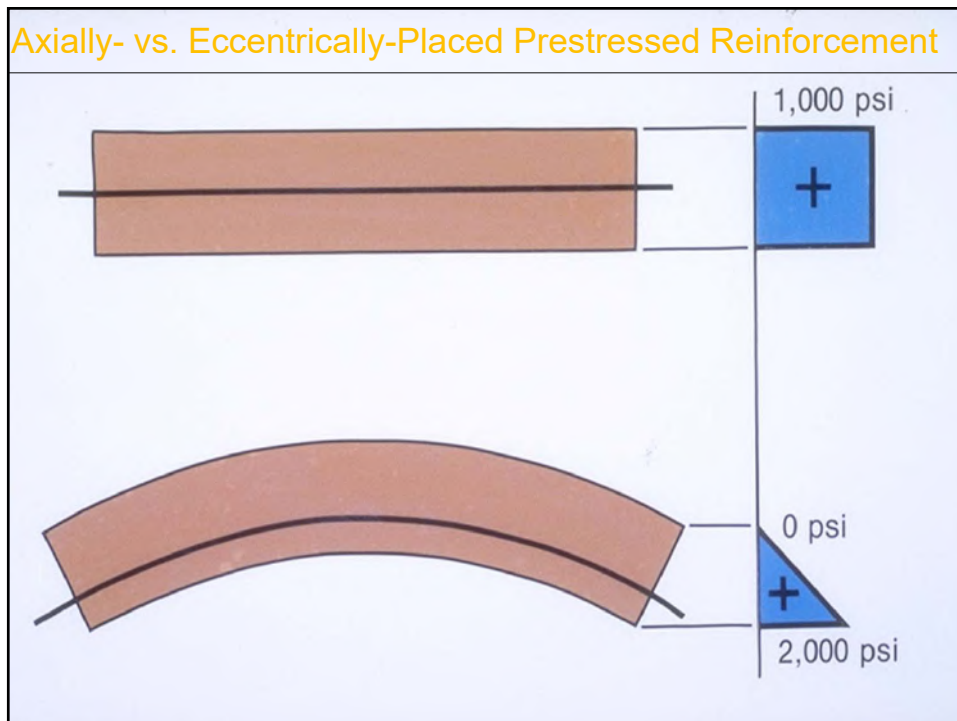

18

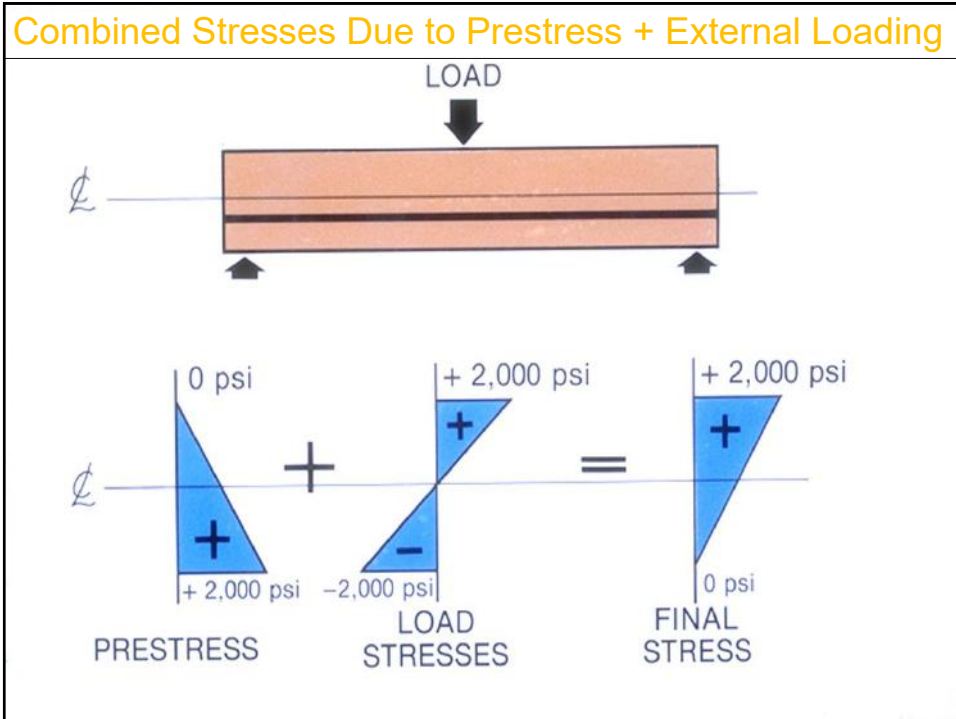

19

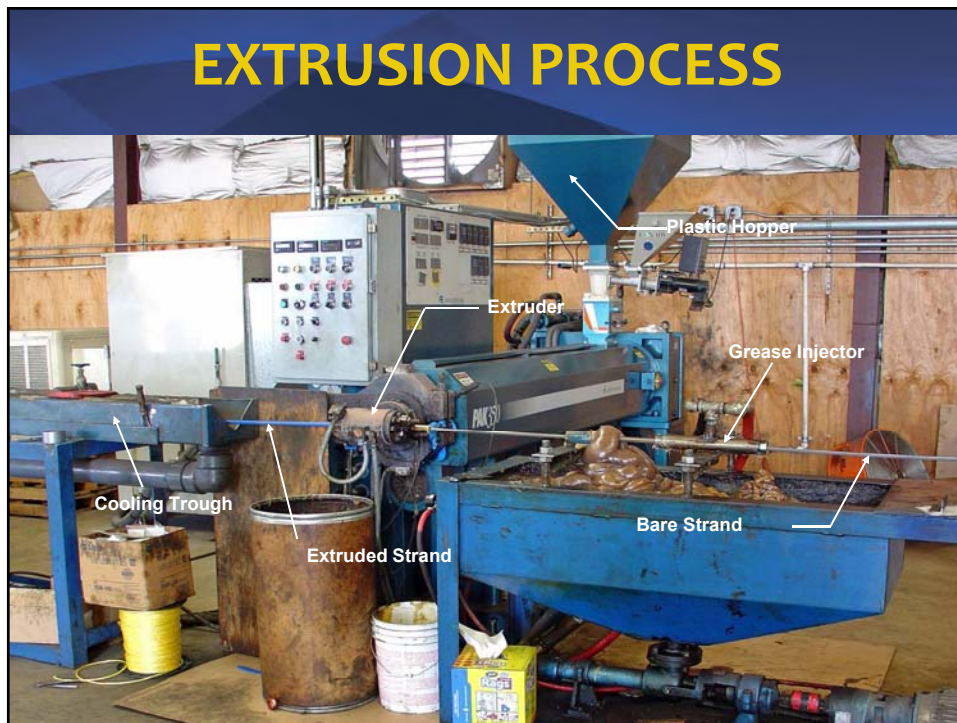

20

FABRICATION

- Cutting of tendons to length



21

FIXED-END ANCHOR

Pull Installation

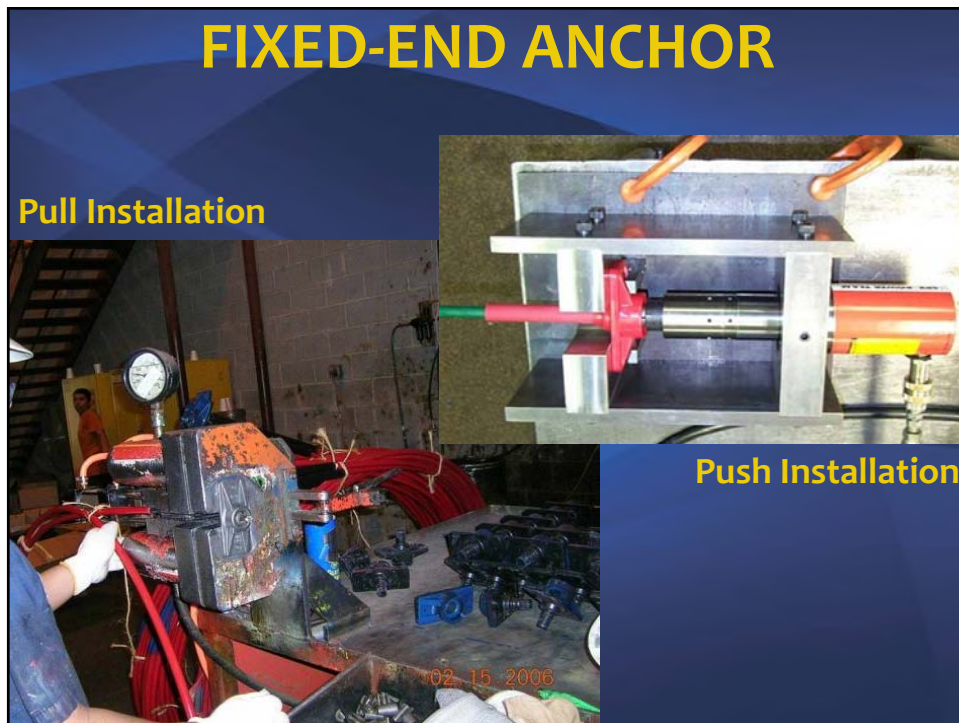

Push Installation

02.15.2006

22



23



24



25



26



27

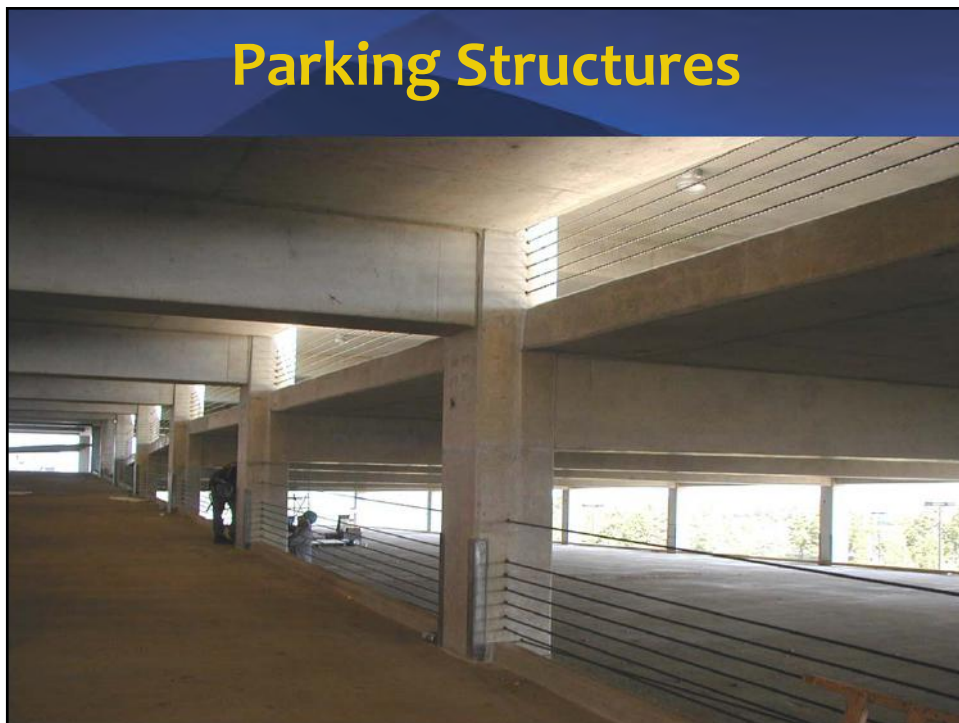

28

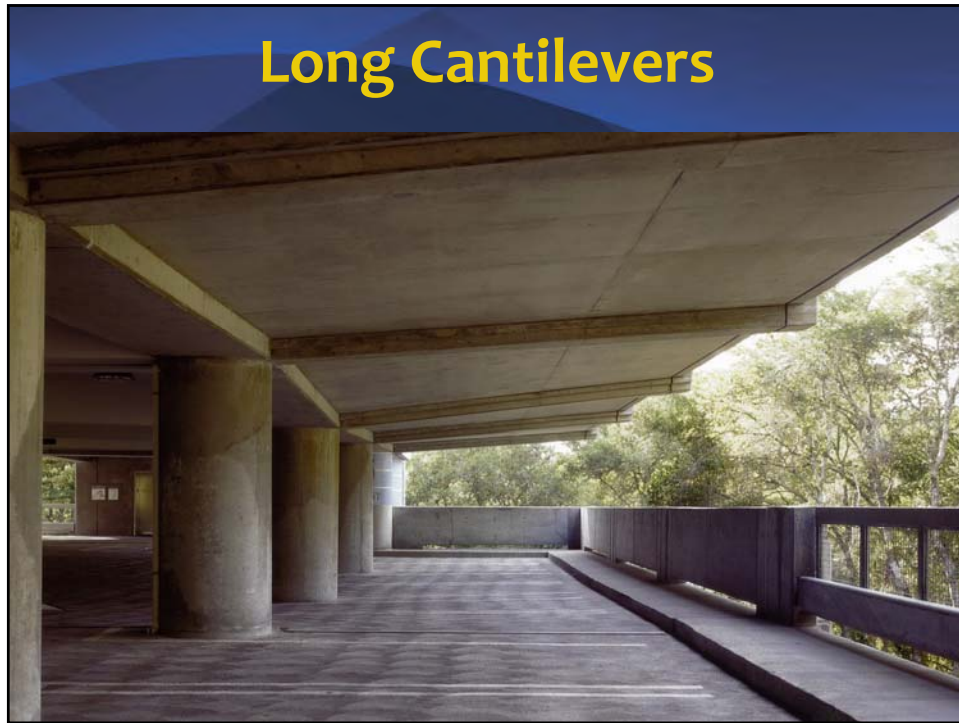

29

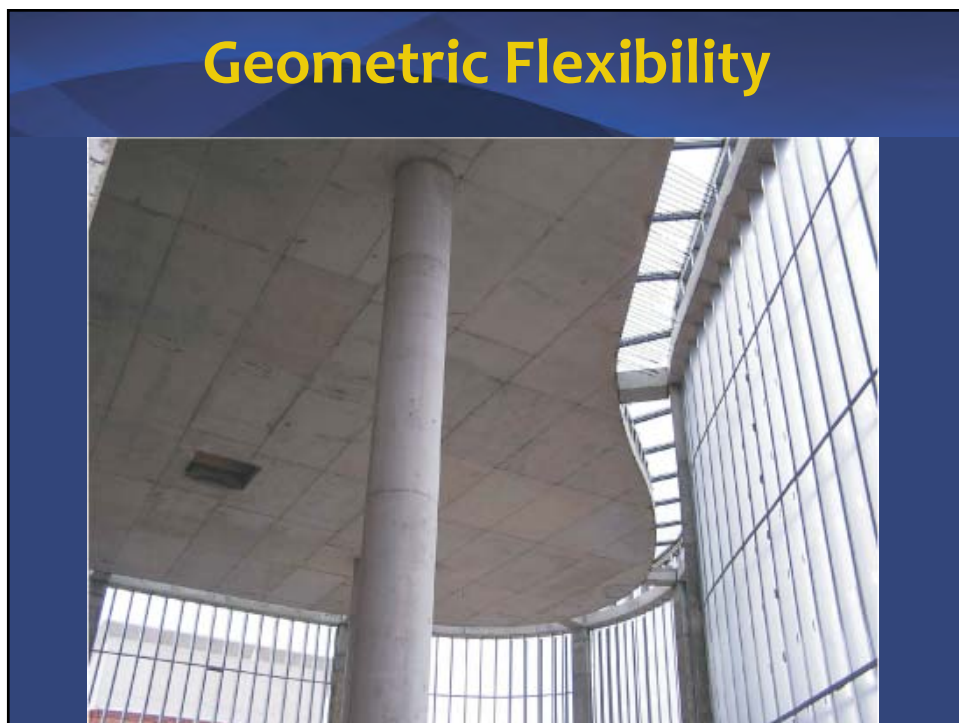

30

Slabs-on-Ground

Residential-Light Commercial

- Ribbed foundations
- Uniform thickness foundations



31

Slabs-on-Ground

- Industrial floors



32



33



34



35



36



37



38

Two-Way Slabs

- Two-way framing action
- Spans typically up to 40 ft (12.2 m) each direction
- Resists lateral loads by frame action
- Can have capitals, drop panels, beams & joist
- Efficient, least depth & material use

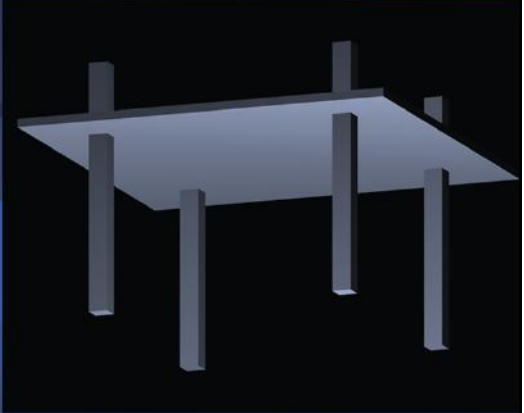

A 3D perspective rendering of a two-way slab. The slab is a flat, light-colored rectangular plate supported by four vertical columns. The columns are arranged in a 2x2 grid. The background is dark blue with a subtle mountain-like silhouette.

39

Two-way Slabs

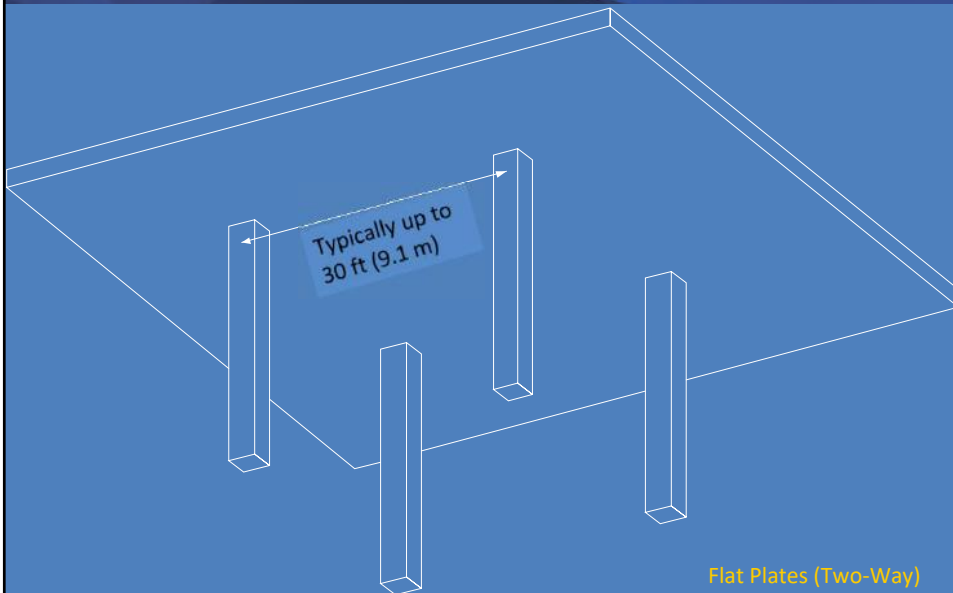

Typically up to 30 ft (9.1 m)

Flat Plates (Two-Way)

A 2D line drawing of a two-way slab. The slab is a white-outlined rectangle supported by four white-outlined columns. A blue callout box with white text points to one of the spans, stating "Typically up to 30 ft (9.1 m)". The background is a solid blue color.

40

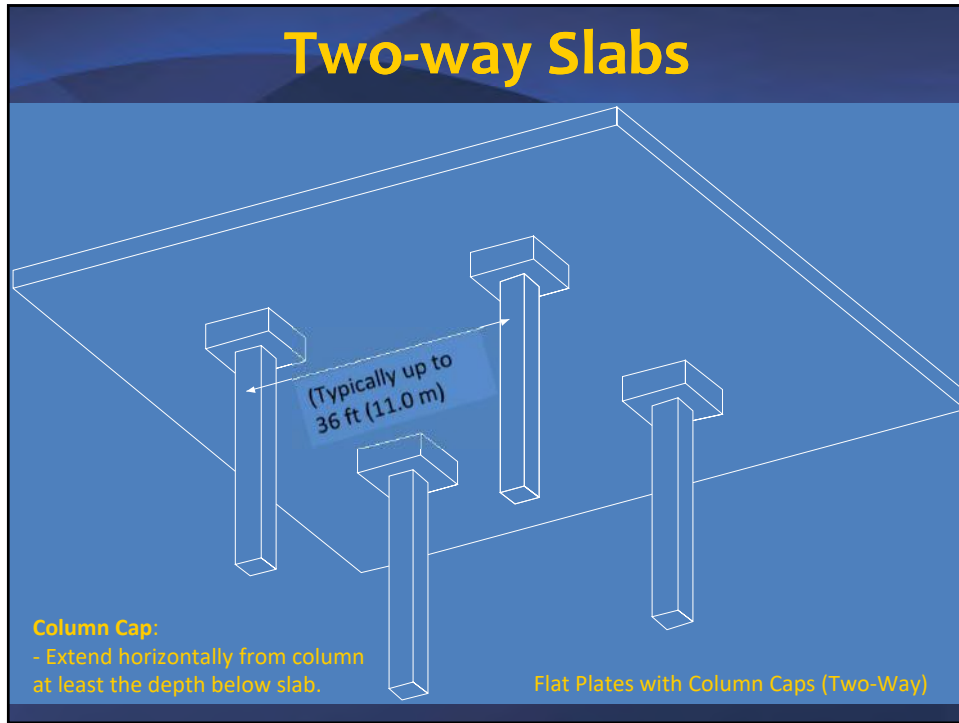

41

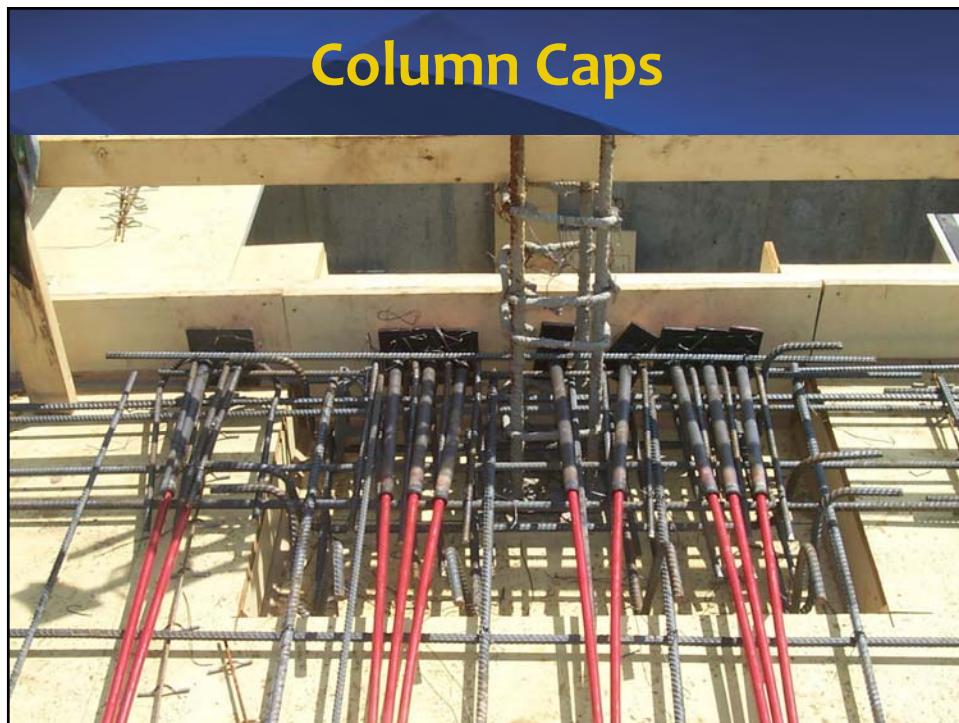

42

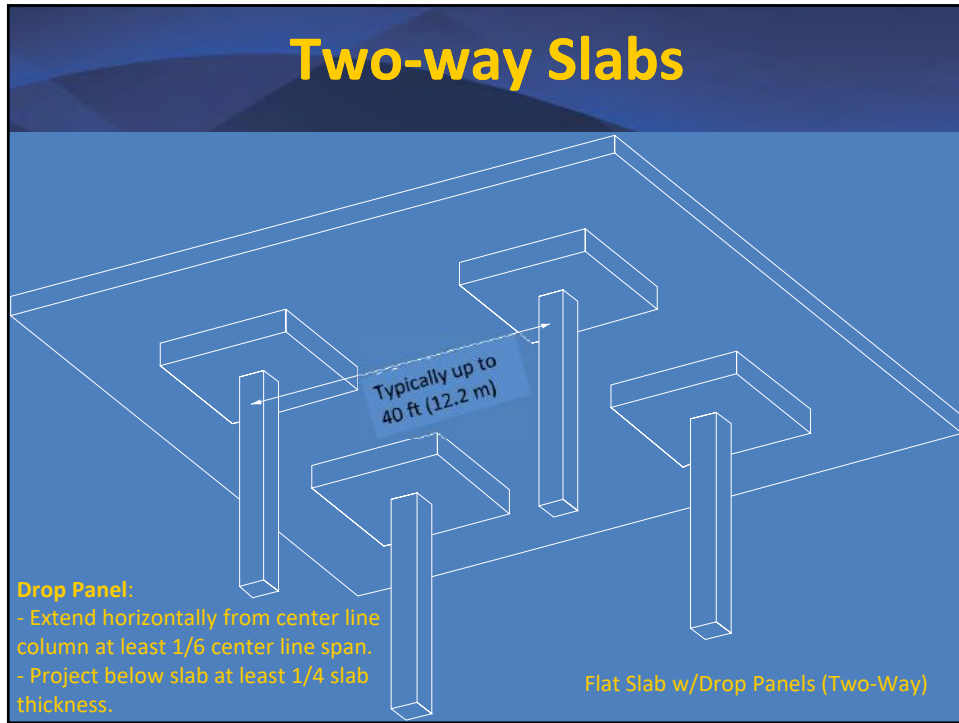

43



44



45



46



47

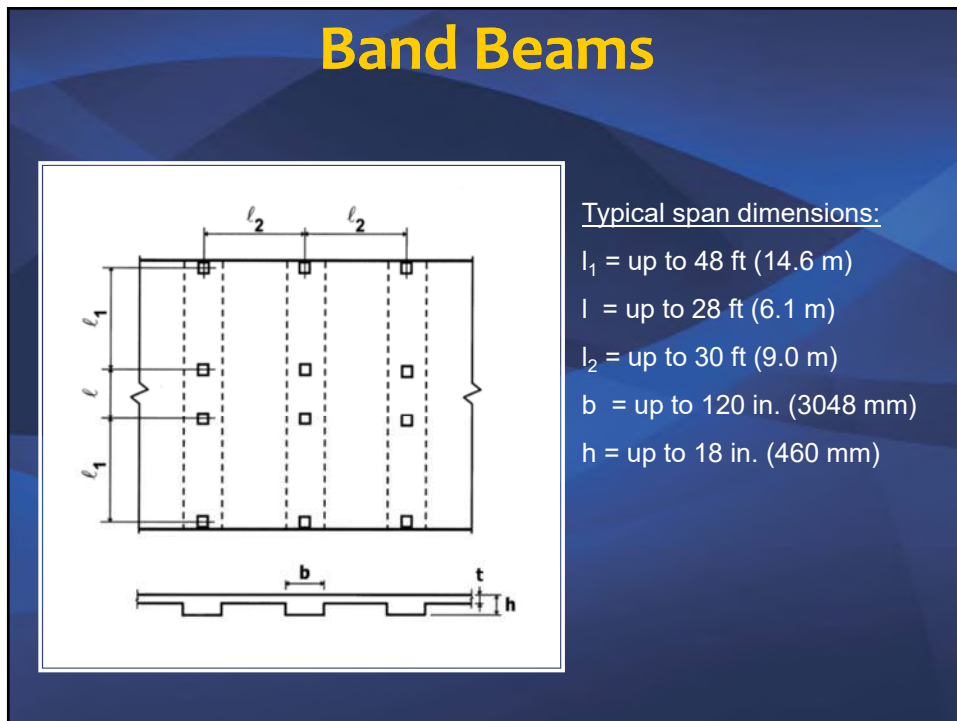

48



49

Beams and One-way Slabs

- One-way framing action
- Beam spans typically up to 65 ft (20 m)
- Slab spans typically up to 30 ft (9.1 m)
- Effective frame action along beam lines
- Clean soffit for mechanical & electrical

A 3D diagram showing a rectangular slab supported by four vertical columns. The slab is shown in a perspective view, with the beams and columns clearly defined.

50

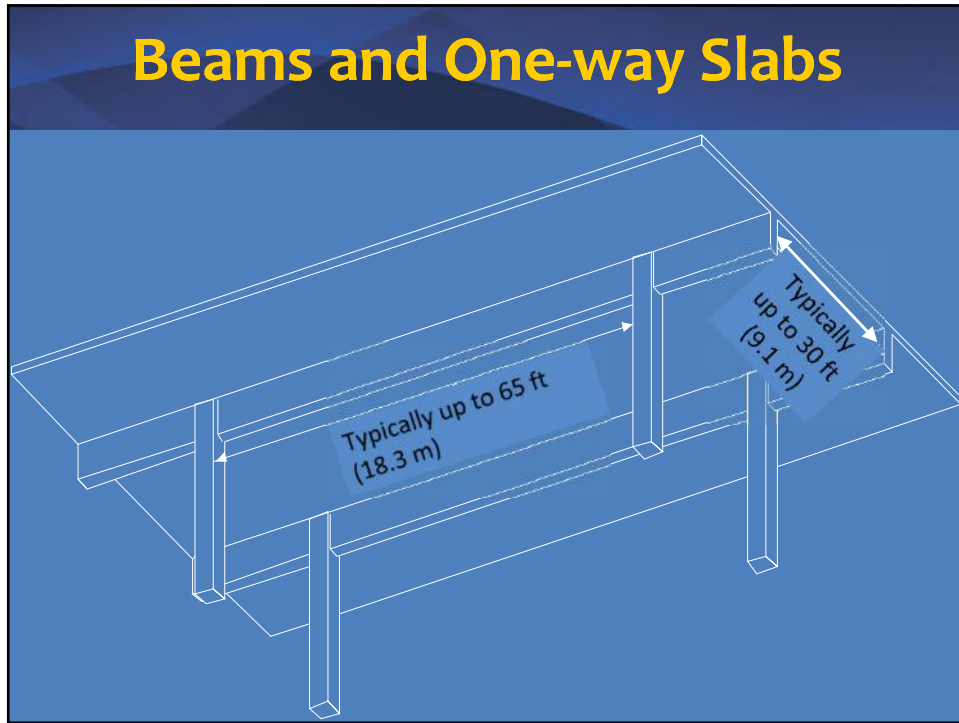

51

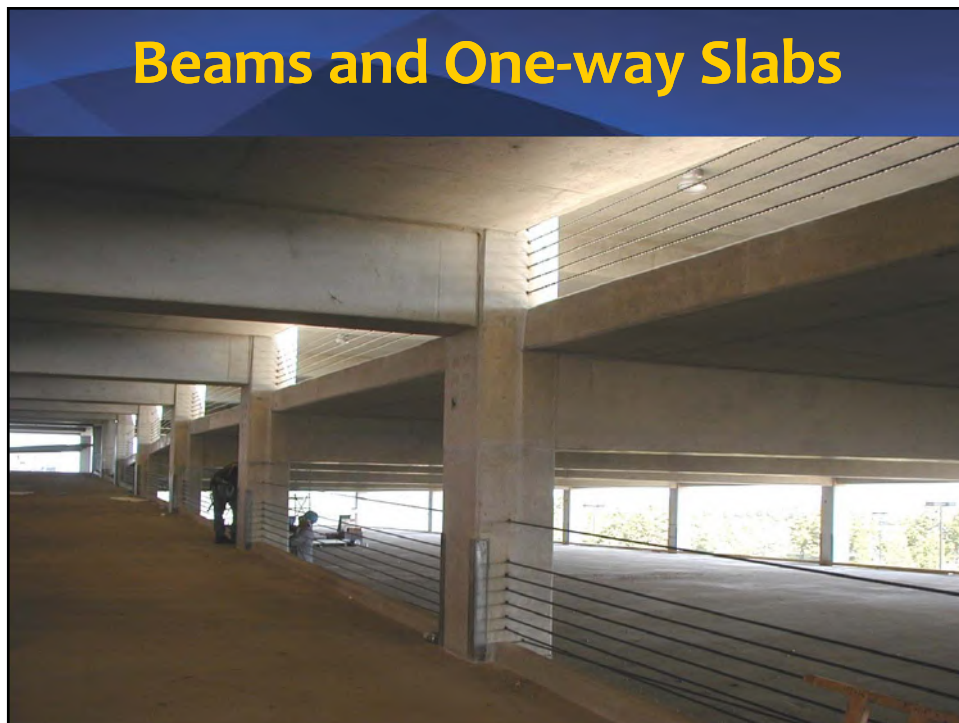

52



53

Beams and Joists

Typical span dimensions:

- Slab up to 10 ft (3.0 m)
- Joist up to 45 ft (13.7 m)
- Beam up to 35 ft (10.7 m)
- Effective frame action in two directions

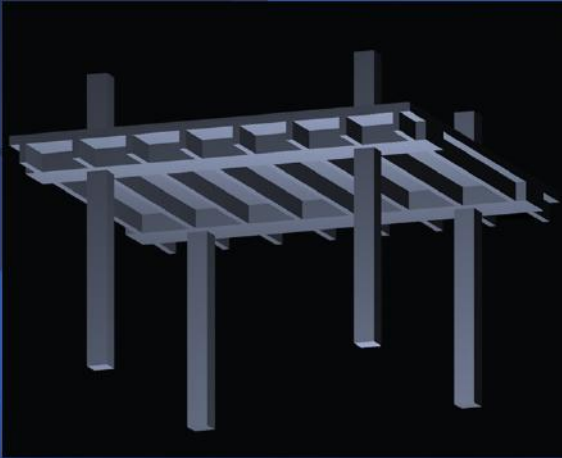

54

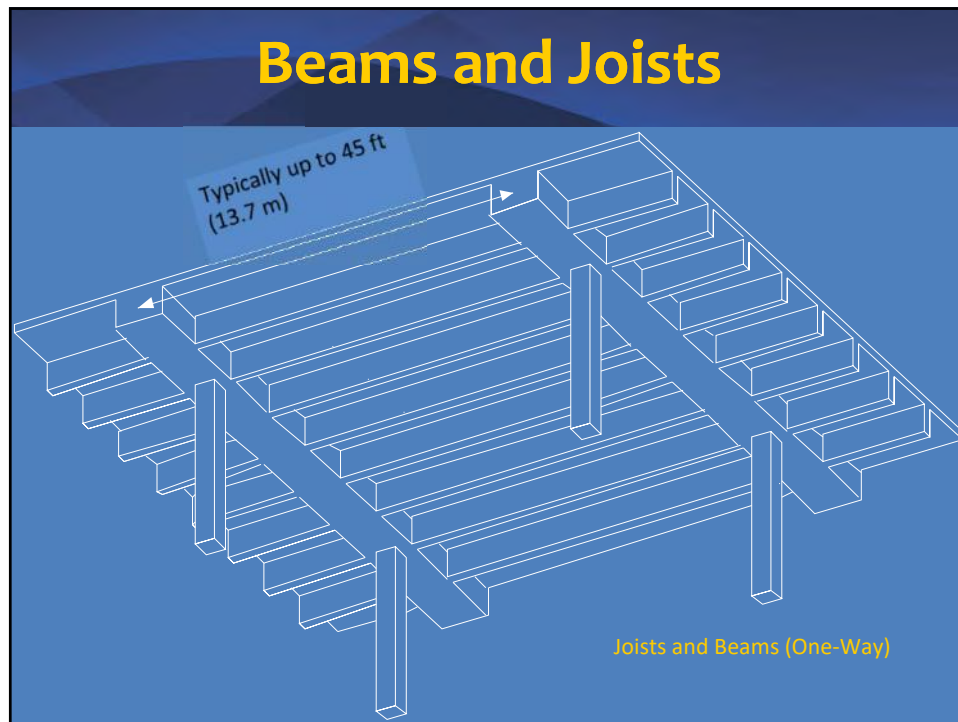

55

PT BASICS

- Load Balancing
- Secondary Moments
- Preliminary Design
- Hands-on Example

56

Basic Definitions: Load Balancing

Concept: Portion of dead load is balanced by counter-active forces in post-tensioning tendons

Counter active tendon forces:

- Axial compression + uplift loads
- Balance a portion of the load on the structure

“Removing” post-tensioning tendons from the structure and replacing the tendon’s influence as a series of equivalent loads

57

Load Balancing

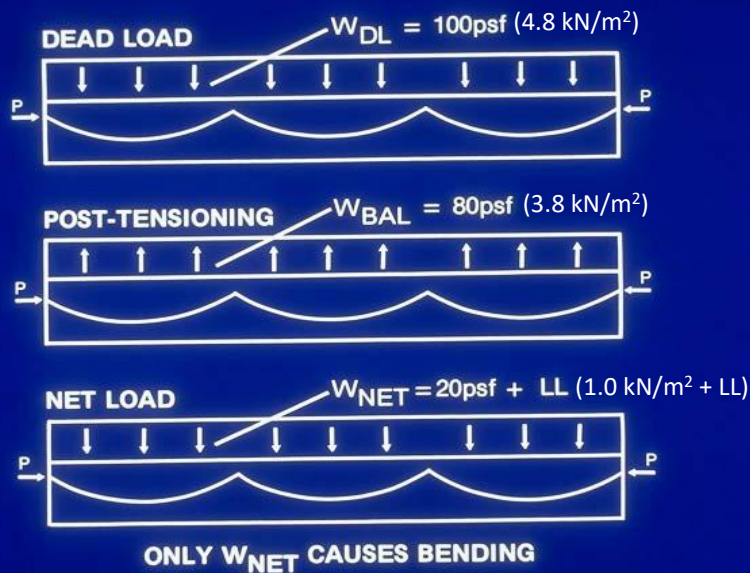

58

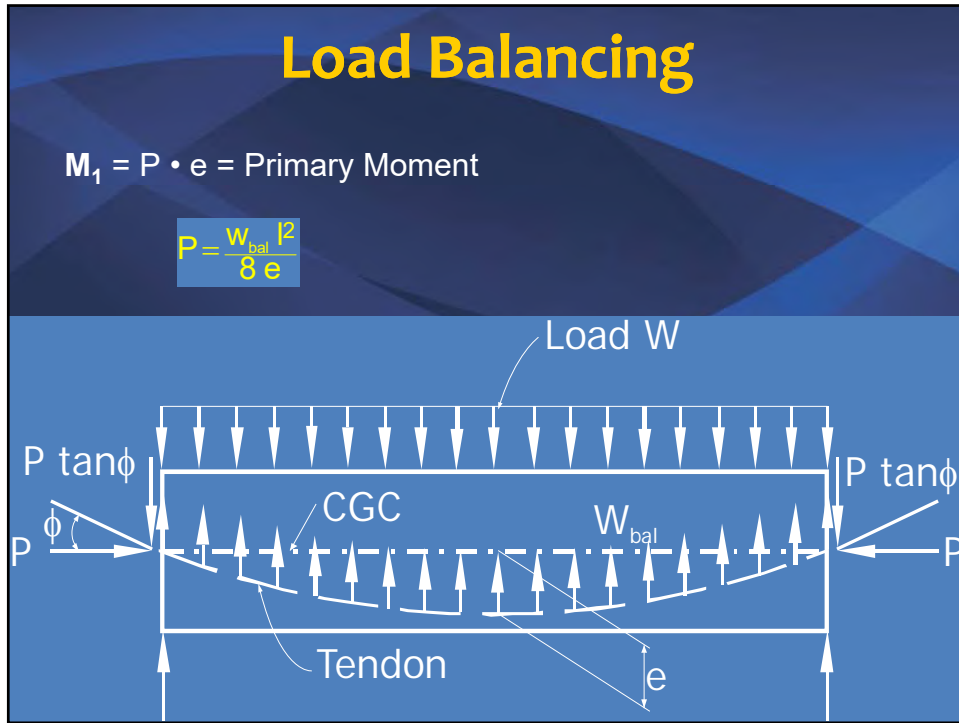

59

Secondary Moments

$M_2 = \text{Secondary Moment}$
 Developed in post-tensioned concrete members due to prestressing forces

Consequence of constraint by the supports to the free movement of the member

- Only develops in indeterminate members
- Simply supported beams have zero secondary moments

Significant: must be accounted for in the design of prestressed concrete indeterminate structures (load factor 1.0 in strength design per ACI 318-14, 5.3.11)

60

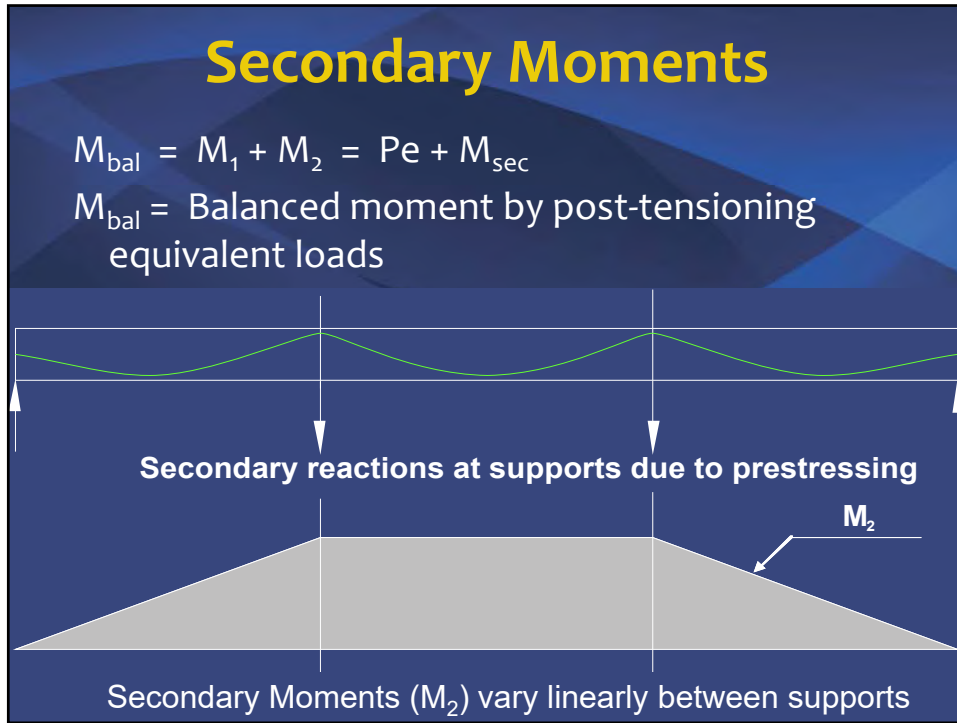

61

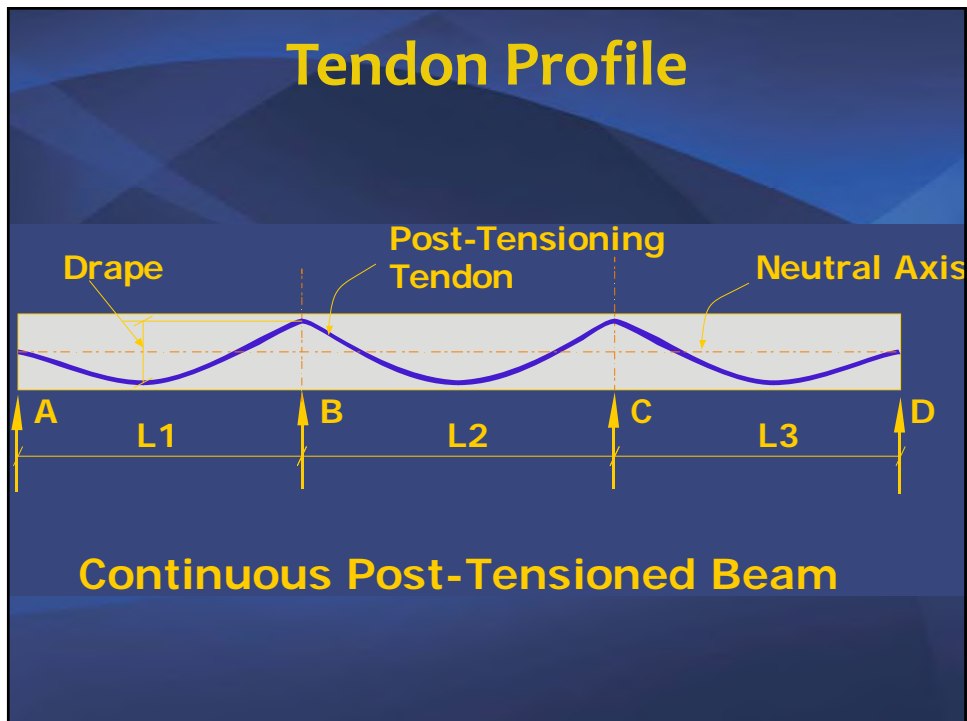

62

NUMERICAL EXAMPLE

Key Concepts

- Secondary Moments
- Equivalent Loads
- Tensile Stress Computation

63

Two-Span Continuous Beam

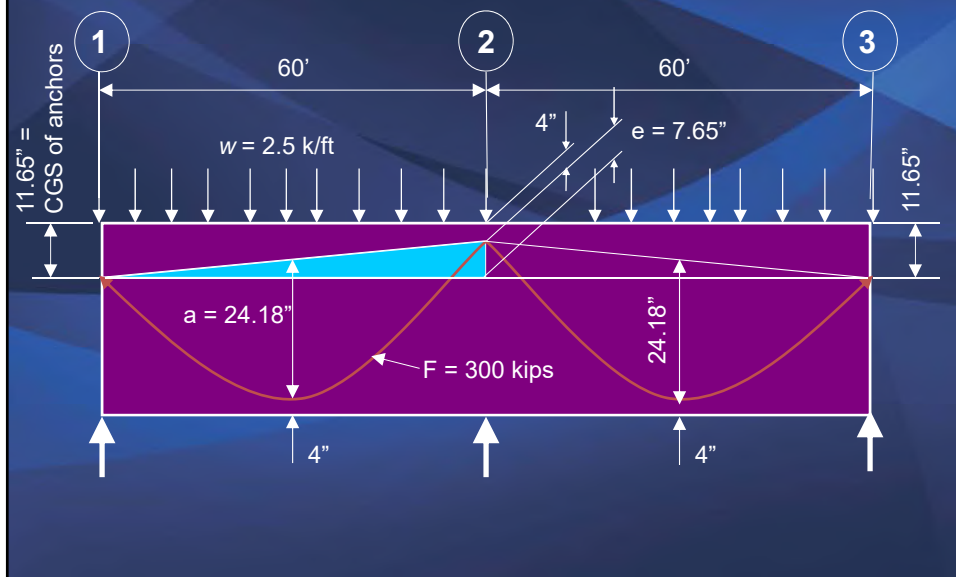

64

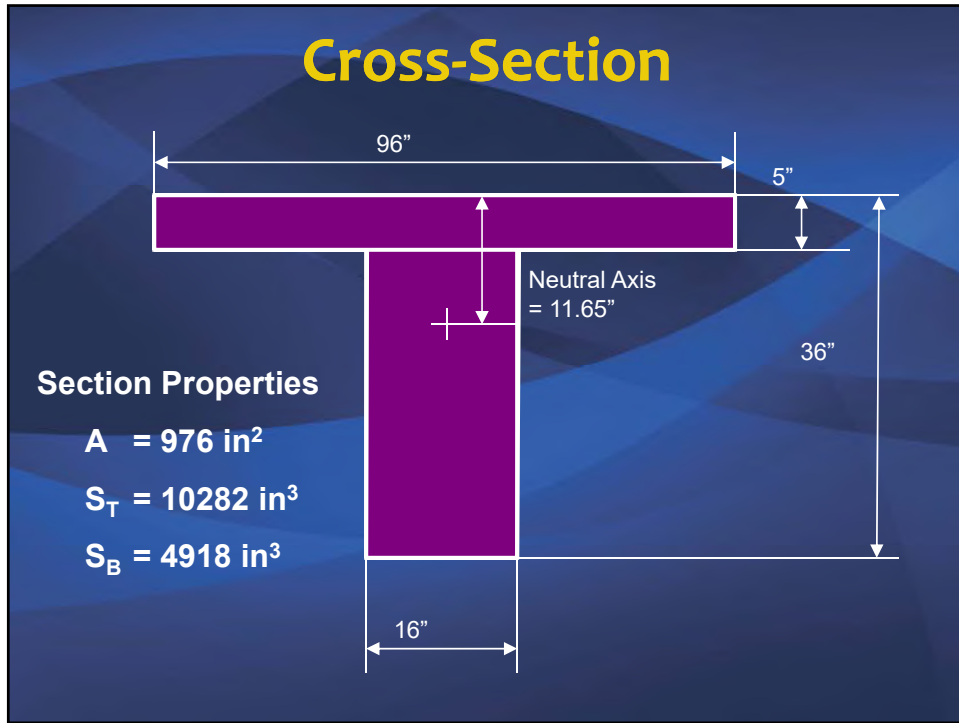

65

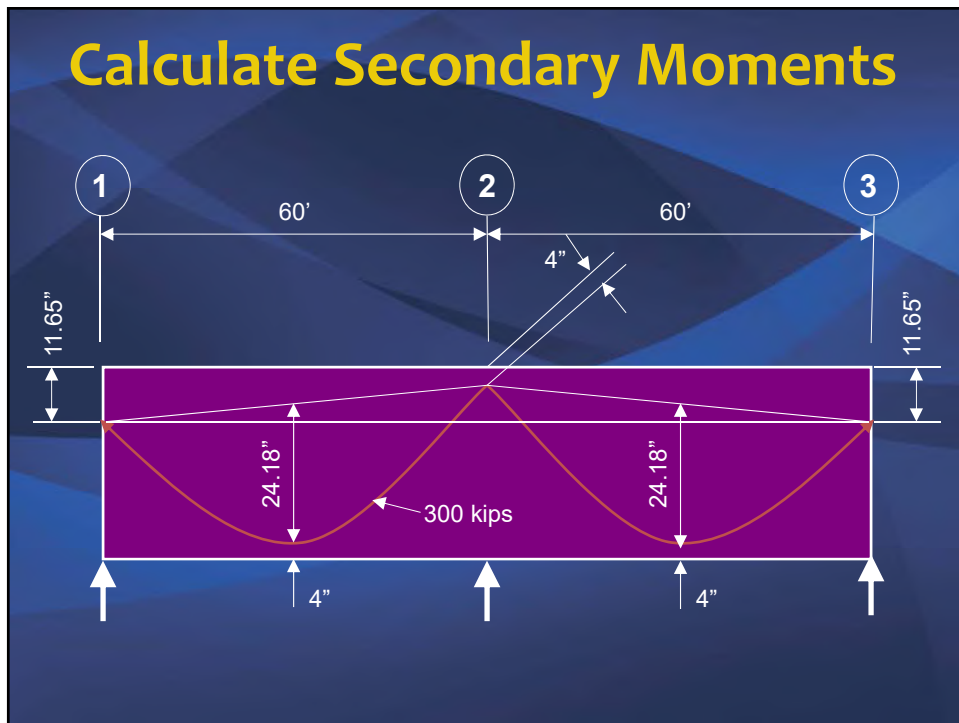

66

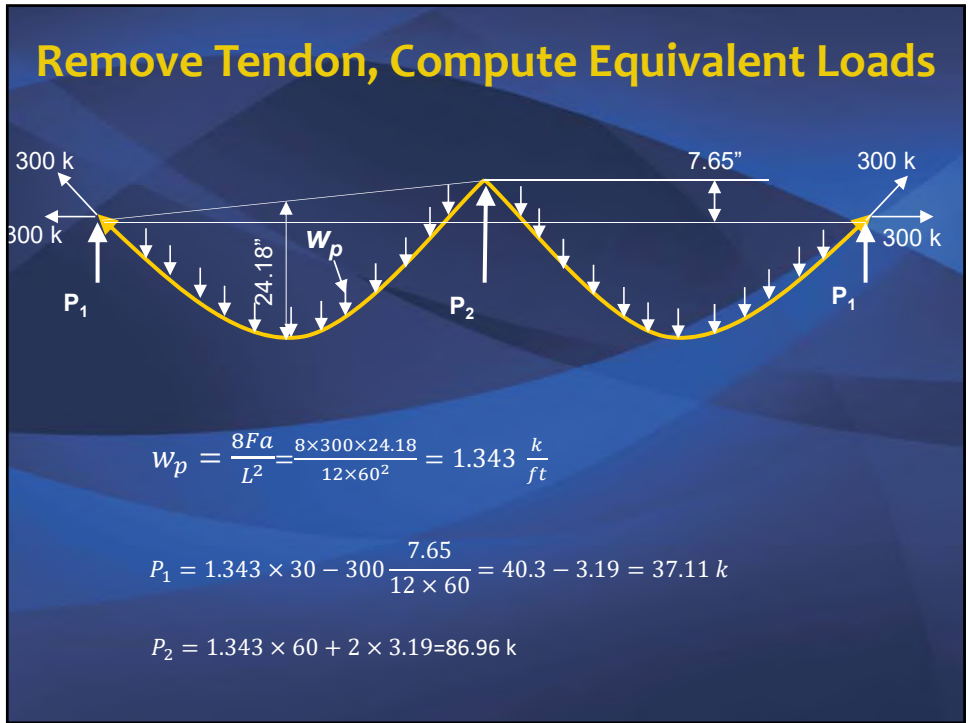

67

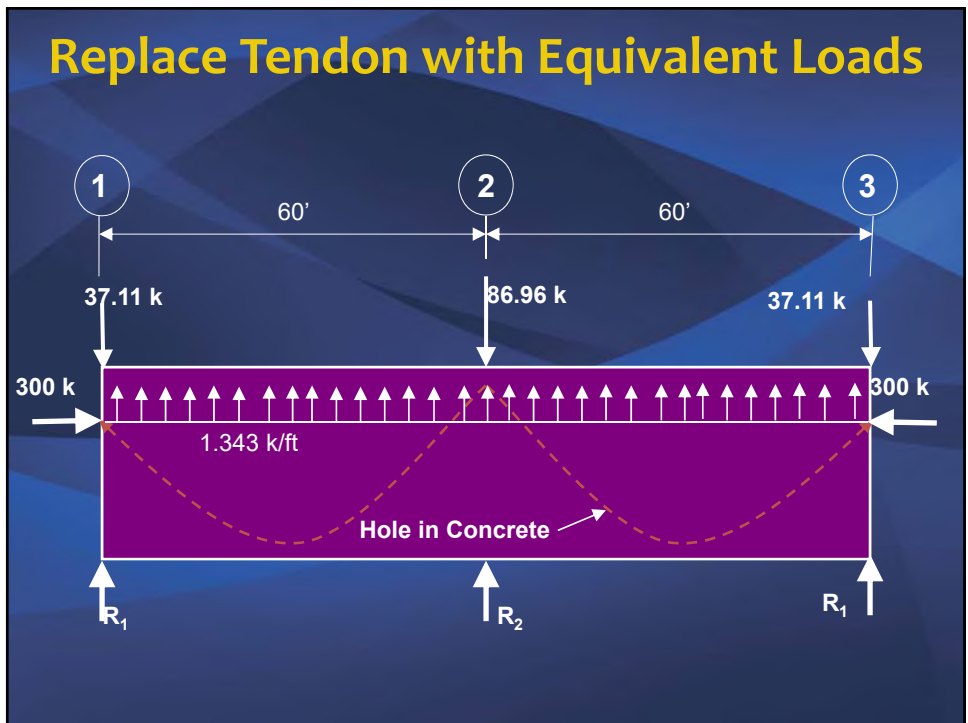

68

Calculate Reactions to Equivalent Loads

Each Reaction has a two components:

1. Equilibrates the concentrated load
2. Equilibrates the uniform balanced load

$$R_1 = 37.11 - \frac{3}{8} \times 1.343 \times 60 = 37.11 - 30.22 = 6.89 \text{ k}$$

$$R_2 = 86.96 - 1.25 \times 1.343 \times 60 = 86.96 - 100.73 = -13.77 \text{ k}$$

69

Put Tendon Back in Beam

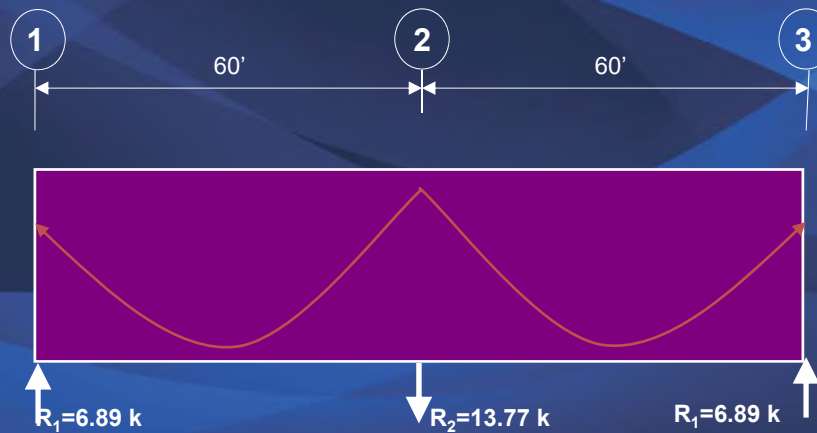

70

Secondary Reactions and Moments

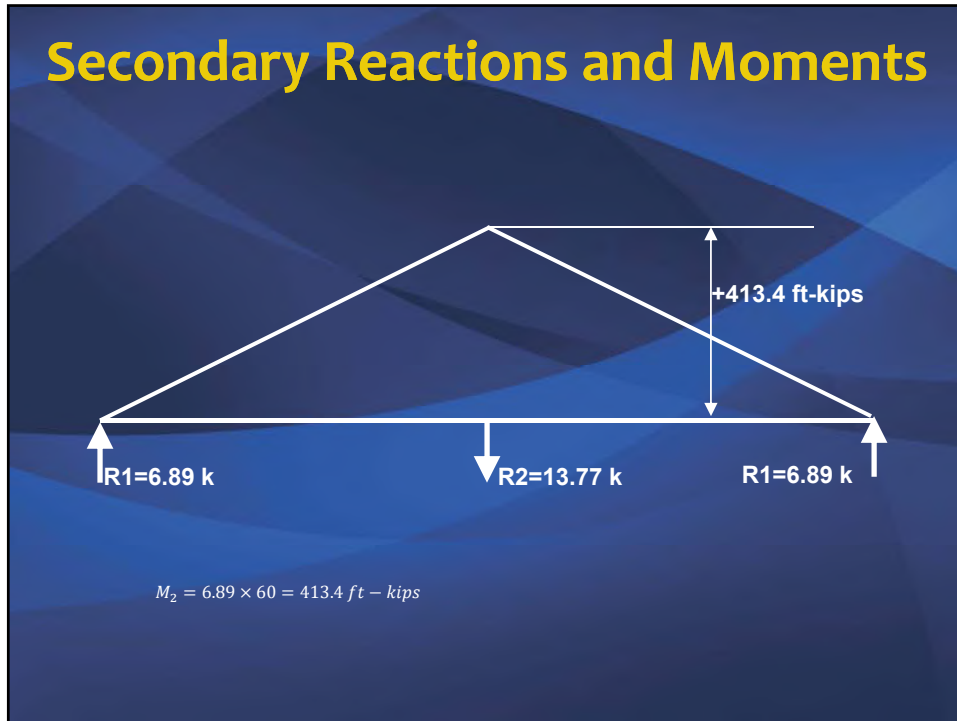

71

The Easy Way

$$M_2 = M_{bal} - Fe$$

$$M_2 = \frac{1.343 \times 60^2}{8} - 300 \frac{7.65}{12}$$

$$= +413.1 \text{ ft-kips}$$

72

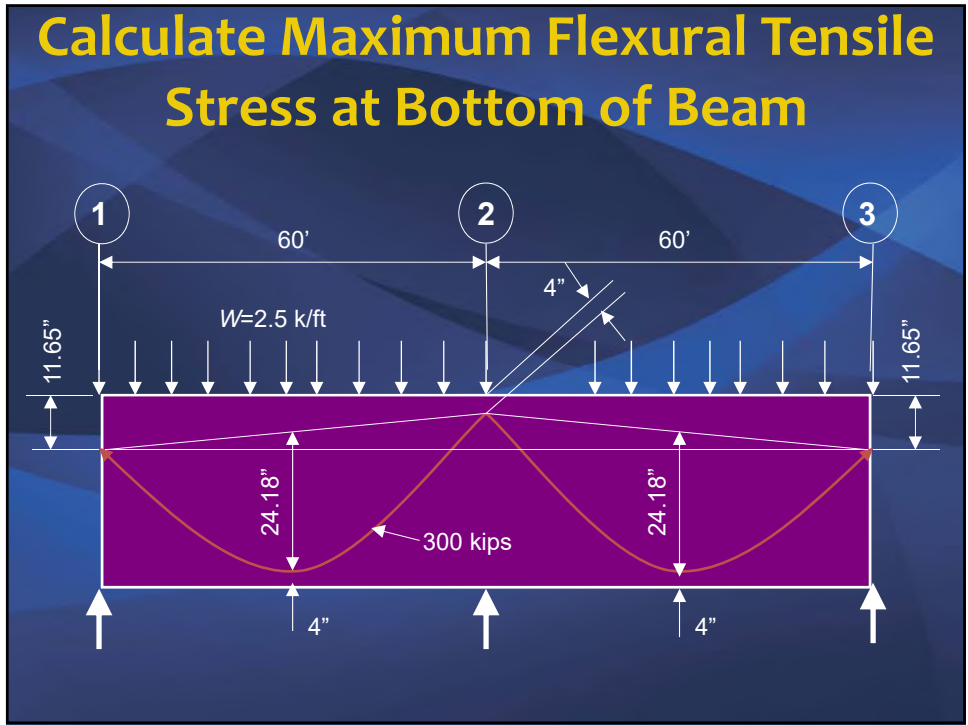

73

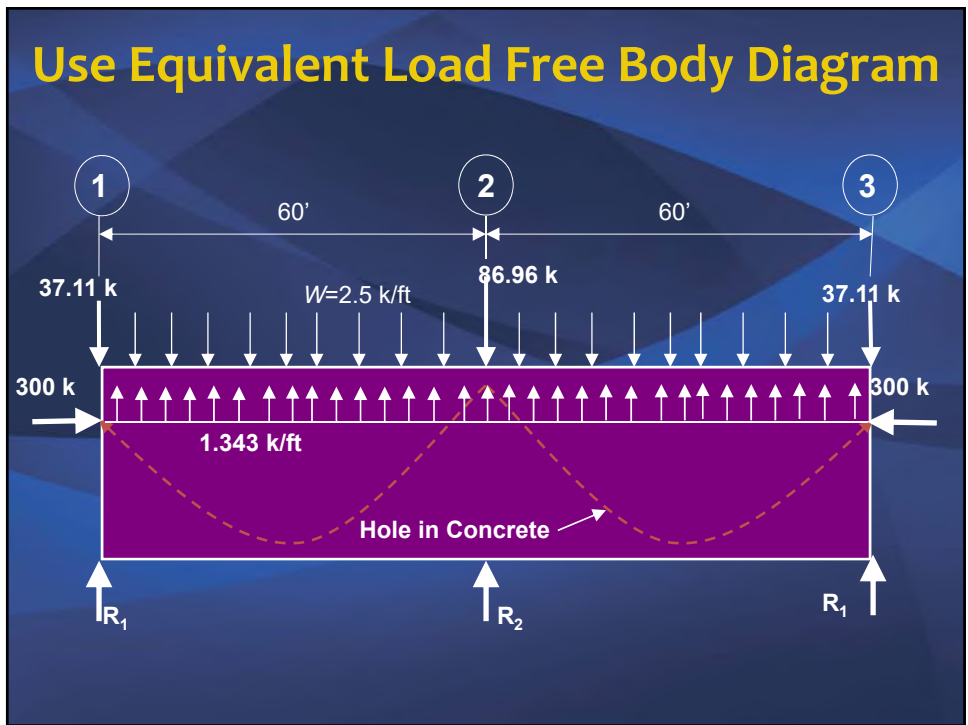

74

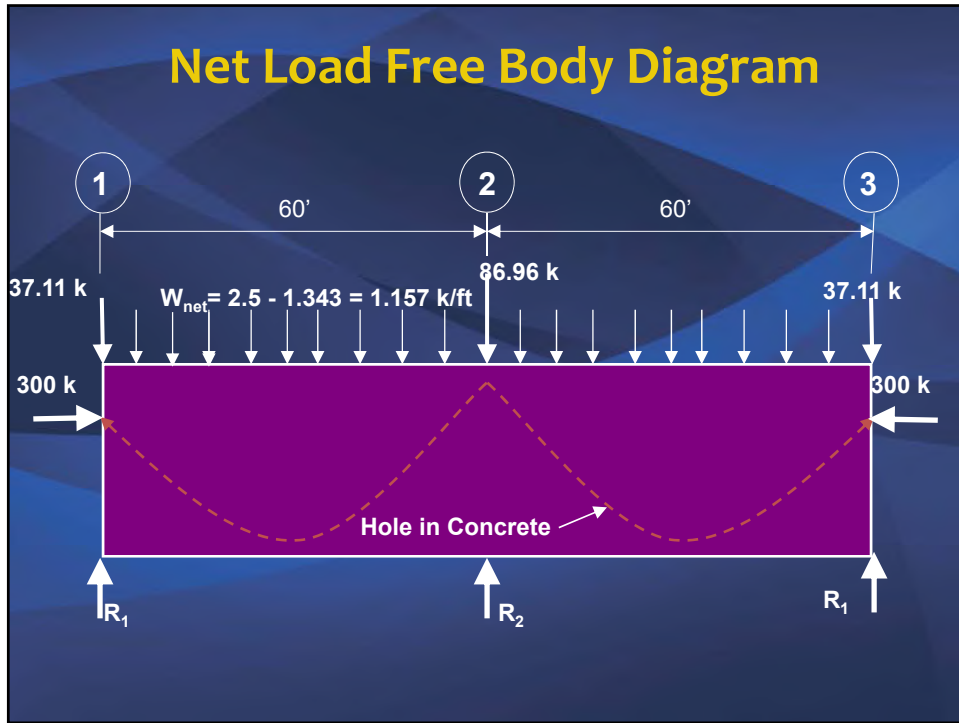

75

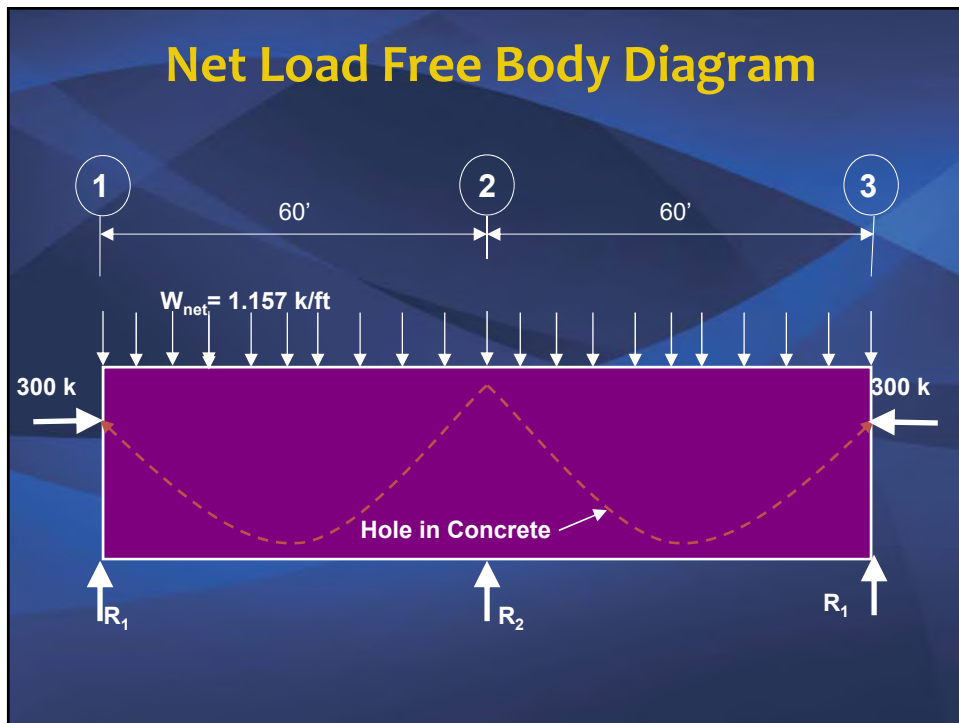

76

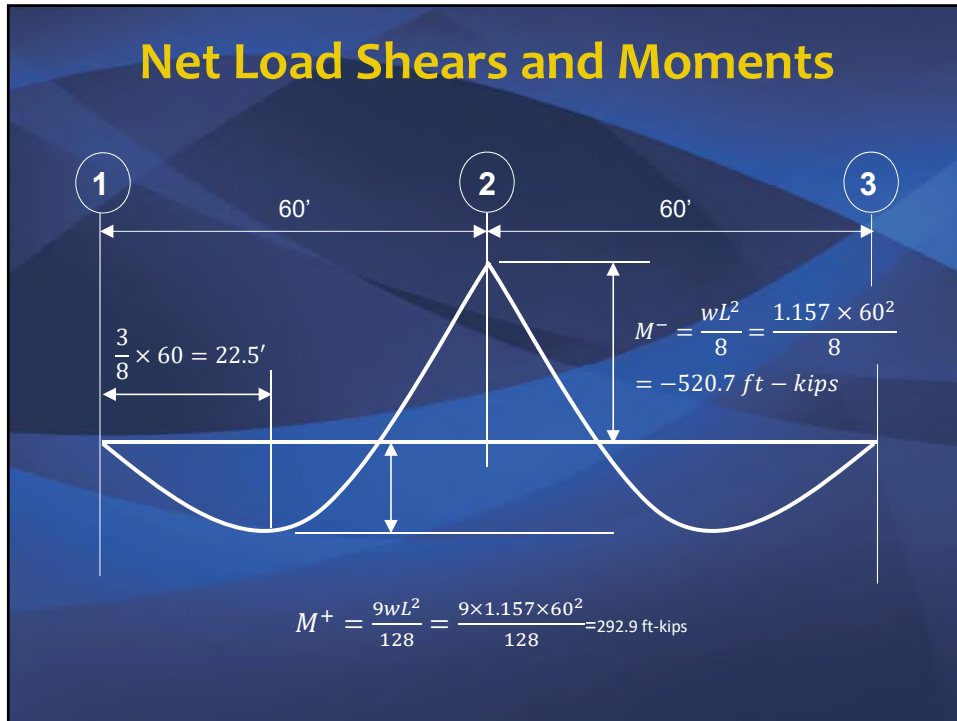

77

Maximum Flexural Tensile Stress at Bottom of Beam

Occurs at point of max. positive net moment
($M_{net}^+ = +292.9 \text{ ft-k} @ x=22.5' \text{ from Point A}$):

$$f = -\frac{F}{A} + \frac{M_{net}}{S_B} = -\frac{300}{976} + \frac{292.9 \times 12}{4918}$$

$$= -0.307 + 0.714 = +0.407 \text{ ksi}$$

78

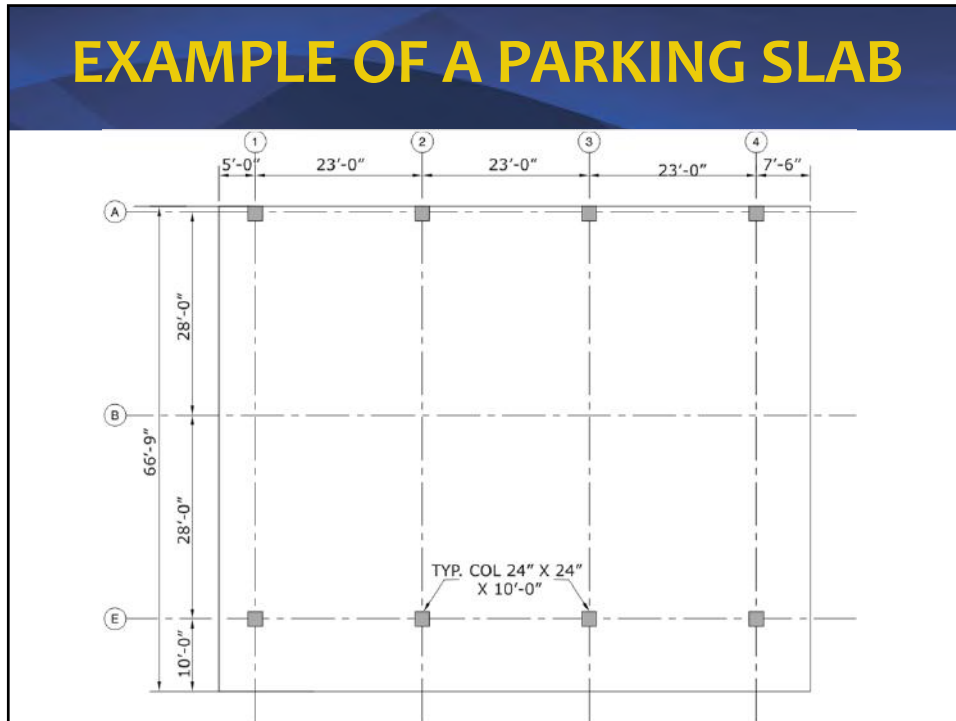

79

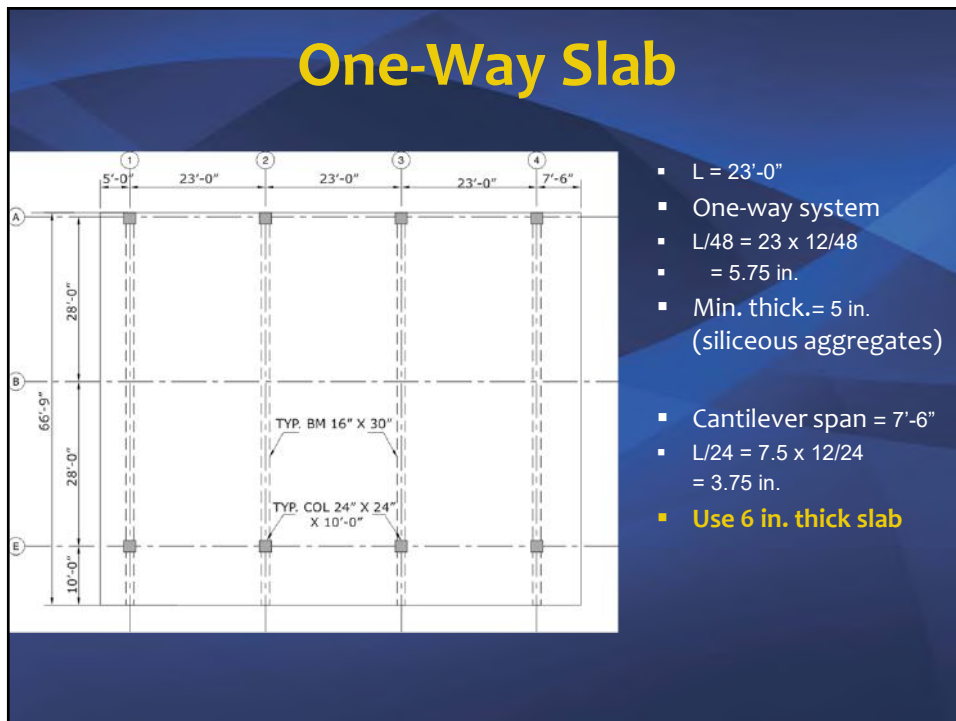

80

Prestressing Force and Profile

Typical Span (Interior)

- $CGS_{Bot} = \frac{3}{4} + \frac{1}{4} = 1$ in.
- $CGS_{TOP} = 1\frac{1}{4} + \frac{1}{4} = 1\frac{1}{2}$ in. (**Larger cover at top**)
- $e = 6 - 1 - 1.5 = 3.5$ in.

- $DL = 6 \times 150/12 = 75$ psf + 5 psf finishes
- Balance 70% of DL $W_{bal} = 56$ psf

$$P = \frac{W_{bal} l^2}{8 e}$$

- $P = 56 \times 23^2 / (8 \times 3.5/12) = 12,700$ plf
- Use 13 k/ft of force in interior spans
- $13,000 / (6 \times 12) = 180$ psi (OK!)

81

Prestressing Force and Profile

Left Exterior Span

- Top CGS = $1\frac{1}{4} + \frac{1}{4} = 1\frac{1}{2}$ in. (interior support)
- Top CGS = 2.5 in. (exterior support) **Assumed!**
- Bottom cover = $1\frac{1}{2} + \frac{1}{4} = 1\frac{3}{4}$ in.
- $e = 6 - ((2.5 + 1.5)/2 + 1.75) = 2.25$ in.

$$P = \frac{W_{bal} l^2}{8 e}$$

- $P = 56 \times 23^2 / (8 \times 2.25/12) = 19,750$ plf
- Use 20 k/ft

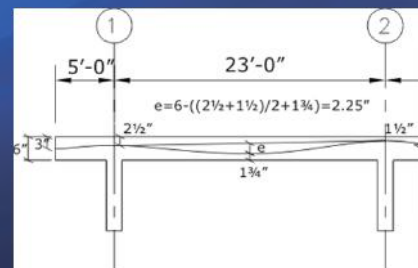

82

Check Cantilever

Check Cantilever for Overbalance

- $e = 3 - 2.5 = 0.5$ in.
- $$W_{bal} = \frac{2 \times 20,000 \times \frac{0.5}{12}}{5 \times 5}$$
- $W_{bal} = 66.7$ psf = $w_{bal}/w_{DL} = 66.7/80 = 83\%$ OK!

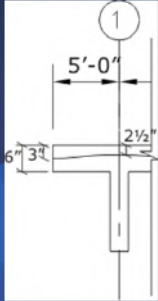

$$P = \frac{w_{bal} l^2}{2e}$$

- If overbalanced then revise eccentricity at support and
- Recalculate post-tensioning force in ext. span

83

Prestressing Force and Profile

Right Exterior Span

- Top Cover = $1\frac{1}{4} + \frac{1}{4} = 1\frac{1}{2}$ in. (interior support)
- Top Cover = 1.5 in. (exterior support) **Assumed!**
- Bottom cover = $1\frac{1}{2} + \frac{1}{4} = 1\frac{3}{4}$ in.
- $e = 6 - ((1.5 + 1.5)/2 + 1.75) = 2.75$ in.
- $P = 56 \times 23^2 / (8 \times 2.75/12) = 16,160$ plf
- Use 16.5 k/ft

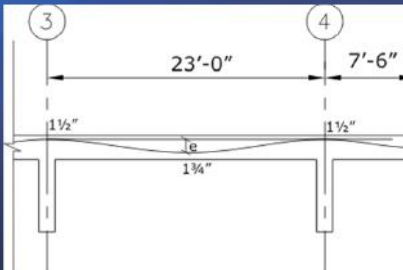

$$P = \frac{w_{bal} l^2}{8e}$$

84

Check Cantilever

Check Cantilever for Overbalance

- $e = 3 - 1.5 = 1.5$ in.
- $$W_{bal} = \frac{2 \times 16,500 \times \frac{1.5}{12}}{7.5 \times 7.5}$$
- $W_{bal} = 73.3$ psf = $(w_{bal}/w_{DL} = 66.7/80) = 91.7\%$ OK!

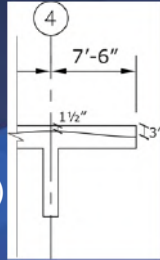

$$P = \frac{w_{bal} l^2}{2e}$$

- If overbalanced then revise eccentricity at support and
- Recalculate post-tensioning force in ext. span

85

Preliminary Design

Preliminary Post-Tensioning Force and Profile

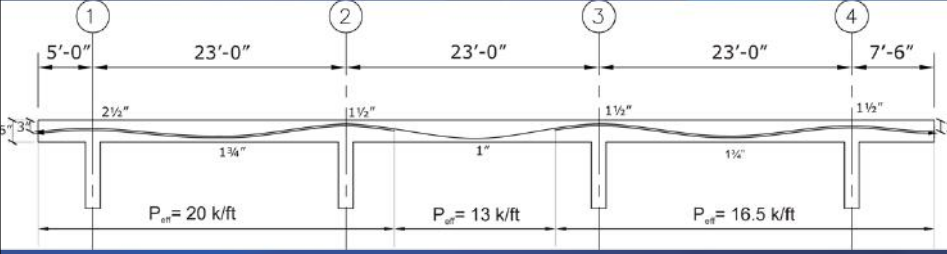

The diagram shows a continuous beam with four supports labeled 1, 2, 3, and 4. The spans between supports are 5'-0" (between 1 and 2), 23'-0" (between 2 and 3), 23'-0" (between 3 and 4), and 7'-6" (between 4 and the end). The beam has a depth of 2 1/2" at support 1 and 1 1/2" at supports 2, 3, and 4. The cable profile is shown with dips of 1 3/4" between supports 1 and 2, 1" between 2 and 3, and 1 1/2" between 3 and 4. The post-tensioning forces are P₀₁ = 20 k/ft, P₀₂ = 13 k/ft, and P₀₃ = 16.5 k/ft.

86

ONE-WAY SLAB

HANDS ON EXAMPLE

- Determine the Slab thickness
- Determine the Tendon Profile and Post-Tensioning Forces
- Estimate the Amount of PT Steel in lb/ft²

87

One-Way Slab

Hands On Example

Determine Thickness

$L = 30'$ One Way Slabs $L/48$

$t = 30 \times 12 / 48 = 7.5$ in Use 8" Thick Slab

$DL = 8/12 \times 150 = 100$ psf

Balance 70% of $DL = 100 \times 0.7 = 70$ psf

Span 1

$e = 8 - (4 + 1) / 2 - 1.75 = 3.75$ in.

$P = 70 \times 30^2 / (8 \times 3.75 / 12) = 25.2$ k/ft

88

One-Way Slab

Hands On Example

Span 3 $e = 8 - (4+1)/2 - 1.75 = 3.75 \text{ in.}$

$$W_{\text{bal}} = \frac{8 \times 25,200 \times \frac{3.75}{12}}{27^2} = 86.4 \text{ psf OK!}$$

Span 2 Balance 100% of DL

$$e = \frac{W_{\text{bal}} l^2}{8P} = \frac{100 \times 15^2}{8 \times 25,200} = 0.11' = 1.34''$$

Use $e = 1.25''$
Cover at Mid = $8 - 1 - 1.25 = 5.75''$

89

DESIGN STEPS / ANALYSIS

- Preliminary Design
- Serviceability
- Strength

90

Planning and Design of PT Systems

- Planning
 - Architectural Criteria
 - Shape, Spans, Occupancy
 - Exposure and Durability Criteria
- General Design Objectives
 - Governing Codes
 - Criteria in Excess of Code

91

Conceptual Design Phase

- Determine Floor System
- Coordinate Structural Geometry
- Determine Member Sizes
- Determine Loading
 - Dead Load
 - Live Load
 - Lateral Loads (if applicable)

92

Conceptual Design Phase (Continued)

- Conceptual Design Phase
- Design Development
 - Material and Cross-Sectional Properties
 - Set Design Parameters
- Design and Analysis
 - One-Way Systems
 - Two-Way Systems
- Construction Documents
 - Layout of Reinforcement
 - Drawing and Detailing

93

PT BEHAVIOR

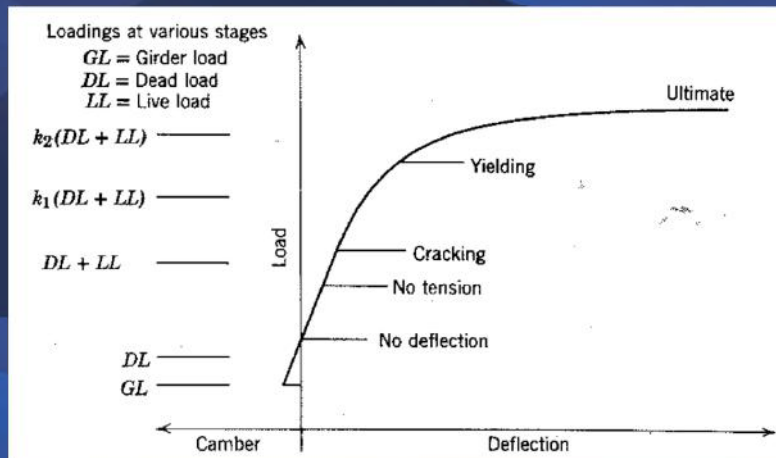

Ref: Design of Prestressed Concrete Structures by T.Y. Lin and Ned Burns

94

STRUCTURAL MODELING TECHNIQUES

Two-Way Slabs

- DO NOT use simplified analysis using coefficients (Direct Design Method)
- DO NOT use middle/column strip concept
- Use the Equivalent Frame Method, EFM, permitted by ACI 318-19 in Sec. 8.2.1; covered in Sec. 8.11 of ACI 318-14, excluding Sec. 8.11.6.5 and 8.11.6.6.
- Apply total tributary width when using EFM
- Finite Element Analysis

95

Equivalent Frame

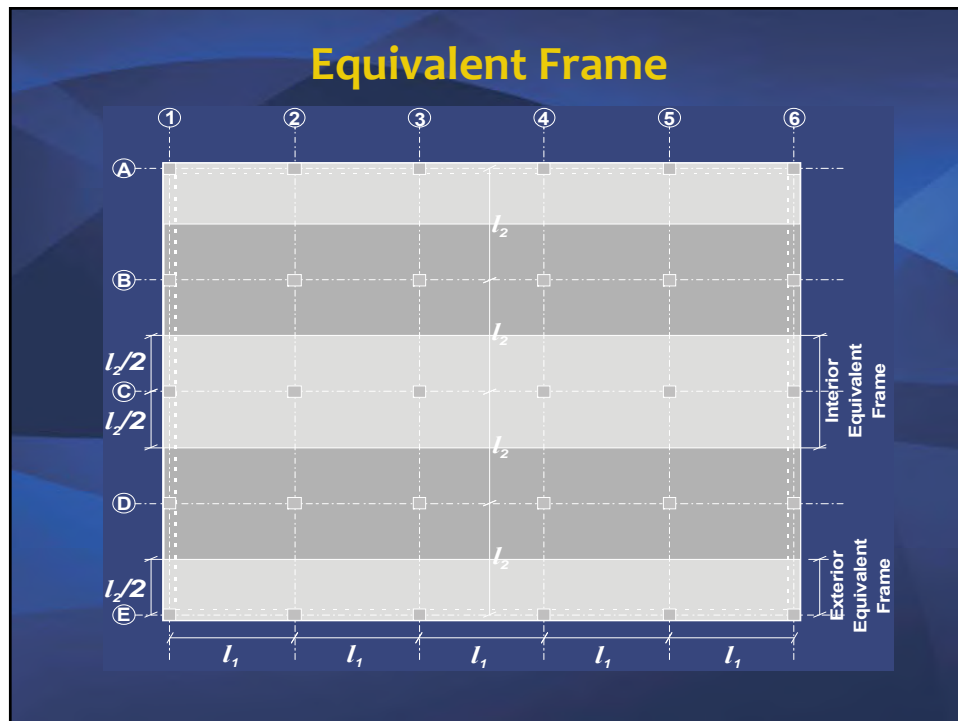

96

BANDED / DISTRIBUTED TENDONS IN 2-WAY SLABS

Banded Tendons:

- **Span length:**
short direction
- **Openings:**
tendon path
- **Cantilevers:**
distributed tendons
- **Column shape:**
as many tendons as possible directly over column



97

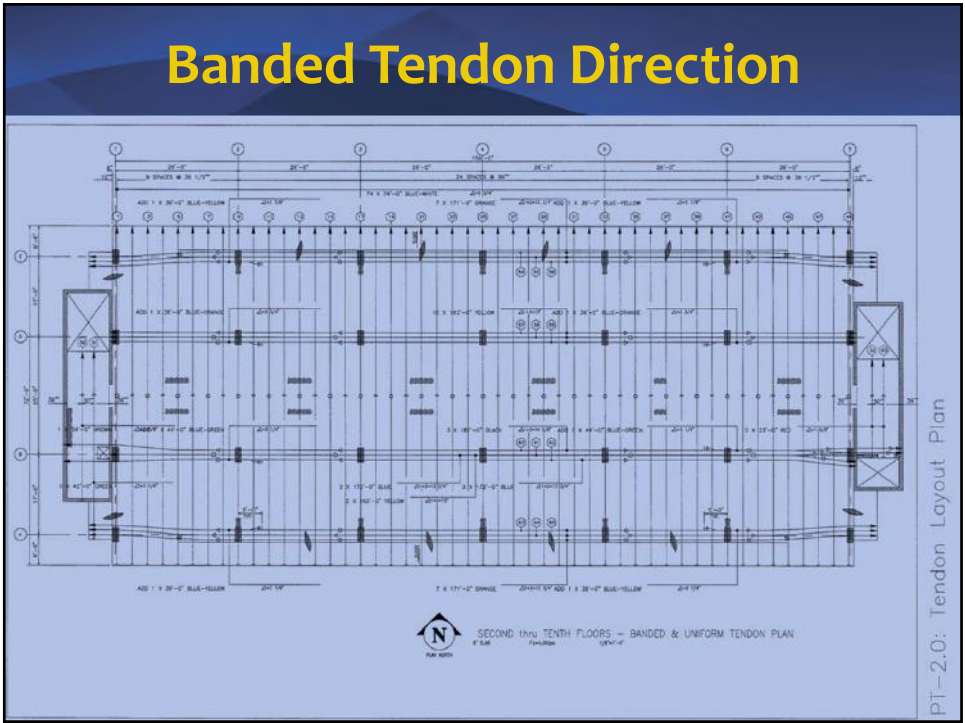

98

Banded / Distributed Tendons in 2-Way Slabs

- PTI Research Project at Virginia Tech (Joined effort PTI – Bekaert)
- Goals:
 - Permit Two-Way Banded PT arrangement
 - Large areas with no PT
 - Remove Sec. 8.7.2.3 from ACI 318

8.7.2.3 For prestressed slabs with uniformly distributed loads, maximum spacing s of tendons or groups of tendons in at least one direction shall be the lesser of $8h$ and 5 ft.

99

DESIGN REQUIREMENTS

- PT structures are designed to satisfy both **serviceability & ultimate** limit states
- Service load design entails:
 - Stresses at working loads are within permissible limits
 - Deflections, vibrations, and cambers are acceptable
 - Crack widths are controlled through the use of non-prestressed reinforcement
 - PT tendons are protected against corrosion

100

Post-Tensioned Reinforcement

- **One-Way Slabs**
 - Provide non-prestressed or prestressed temperature & shrinkage reinforcement (ACI 318-19, Sec. 7.6.4)
 - Typical prestressed (T & S) $P/A = 100$ psi (0.7 MPa)

101

Post-Tensioned Reinforcement

- **Two-Way Slabs**
 - Banded tendons grouped over column lines
 - Distributed tendons uniformly spaced in perpendicular direction
 - Provide 2 continuous strands over columns (ACI 318-19, Sec. 8.7.5.6.1)

102

Nonprestressed Reinforcement

- Provide minimum amount of rebar per ACI 318-19:
 - One-way slabs: Sec. 7.6.2.3 (slabs), 9.6.2.3 (beams)
 - Two-way slabs: Sec. 8.7.5.2
- Add nonprestressed reinforcement per ultimate strength requirements

103

Minimum Positive Moment Bonded Reinforcement for Two-Way Slabs

- Two-way slabs must be designed as Class U
 - ACI 318-19, 8.6.2.3

Table 8.6.2.3—Minimum bonded deformed longitudinal reinforcement $A_{s,min}$ in two-way slabs with bonded or unbonded tendons

Region	Calculated f_i after all losses, psi	$A_{s,min}$, in. ²	
Positive moment	$f_i \leq 2\sqrt{f'_c}$	Not required	(a)
	$2\sqrt{f'_c} < f_i \leq 6\sqrt{f'_c}$	$\frac{N_c}{0.5f_y}$	(b) ^{[1],[2]}
Negative moment at columns	$f_i \leq 6\sqrt{f'_c}$	$0.00075A_{cf}$	(c) ^[2]

104

Minimum Negative Moment Bonded Reinforcement for Two-Way Slabs

ACI 318-19, 8.6.2.3

$$A_s = 0.00075 A_{cf}$$

ACI 318-19, 8.7.5.3

- Placed within 1.5h each side of the column support
- Minimum 4 bars each direction
- Spacing $\leq 12''$ (305 mm)
- Extend a minimum $\ell_n/6$ on each side of support

105

Location of Negative Moment Reinforcement

- Place rebar within an area limited by the column dimension plus 1.5 h on each side; ACI 318-19, 8.7.5.3.
- Place distributed tendons (transverse) below the banded tendons
- #4 (#10 M) bars, typical to match tendon diameter

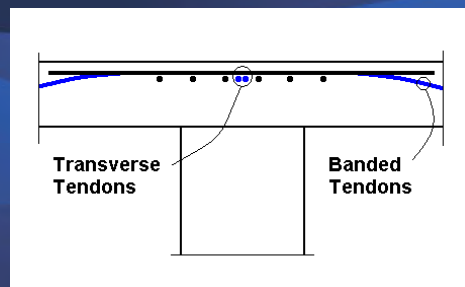

106

Location of Negative Moment Reinforcement



107

PRESTRESS LOSSES

Initial Losses

Friction, F
Elastic shortening, ES
Anchor set (wedge seating), A

Long Term Losses

Concrete shrinkage, S
Concrete creep, C
Post-tensioning steel relaxation, R

108

Friction Losses, F

- Compute force along tendon

$\alpha = \alpha_1 + \alpha_2$

$F_x = F_s e^{-(\mu\alpha + Kx)}$

μ = Coefficient of angular friction (see PT Manual Appendix A.1)
 α = Change in angle between force at anchorage and at x, in radians
 k = Wobble coefficient, per unit length (see PT Manual Appendix A.1)

109

Elastic Shortening

$$ES = 0.5 \frac{E_s}{E_{ci}} f_{cir}$$

E_s = MOE of Prestressing Steel
 E_{ci} = MOE of Concrete.
 $E_{ci} = E_c \left(\frac{days}{28} \right)^{1/2}$
 f_{cir} = Concrete stress at the center of gravity of the prestressing steel due to prestressing force and dead load of beam immediately after transfer.

110

Anchor Set at Transfer, A

Wedge Set:

- Wedges move approximately $\frac{1}{4}$ " (6 mm) into anchor wedge cavity to transfer force from jack to anchor
- Wedge set loss may be significant for short unbonded tendons

111

Steel Wedges

- Lock the strand in the wedge cavity of the anchor after stressing to hold the force
- Made of steel with ductile core to conform to strand shapes; longitudinal cracking is acceptable
- Hardened steel surface with serrated teeth to bite into strand to lock it in elongated state

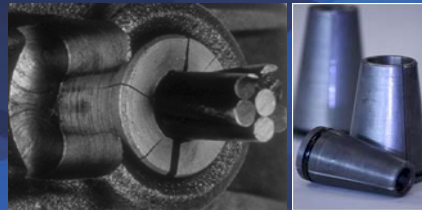

112

Shrinkage

$$SH = 8.2(10^{-6})K_{sh}E_s \left(1 - 0.06 \frac{V}{S}\right) (100 - RH)$$

$\frac{V}{S}$ = Volume to surface ratio
 RH = Relative humidity

Time after end of moist curing to application of prestress								
days	1	3	5	7	10	20	30	60
K_{sh}	0.92	0.85	0.80	0.77	0.73	0.64	0.58	0.45

113

Creep

$$CR = K_{cr} \left(\frac{E_s}{E_c}\right) f_{cpa}$$

$K_{cr} = 1.6$ (post-tensioned)
 f_{cpa} = avg. compressive stress in the concrete at the time immediately after stressing.

Bonded

Unbonded

$$CR = K_{cr} \left(\frac{E_s}{E_c}\right) (f_{cir} - f_{cds})$$

$K_{cr} = 1.6$ (post-tensioned)
 f_{cds} = Stress in concrete due to all superimposed permanent dead loads that are applied top the member after it has been prestressed.

114

Relaxation

$$RE = [K_{re} - J(SH + CR + ES)]C$$

270 Grade Low-lax Strand

$K_{re} = 5000$

$J = 0.040$

f_{pi}/f_{pu}	C (Low-lax Strand)
0.80	1.28
0.79	1.22
0.78	1.16
0.77	1.11
0.76	1.05
0.75	1.00
0.74	0.95
0.73	0.90
0.72	0.85
0.71	0.80
0.70	0.75
0.69	0.70
0.68	0.66
0.67	0.61
0.66	0.57
0.65	0.53
0.64	0.49
0.63	0.45
0.62	0.41
0.61	0.37
0.60	0.33

115

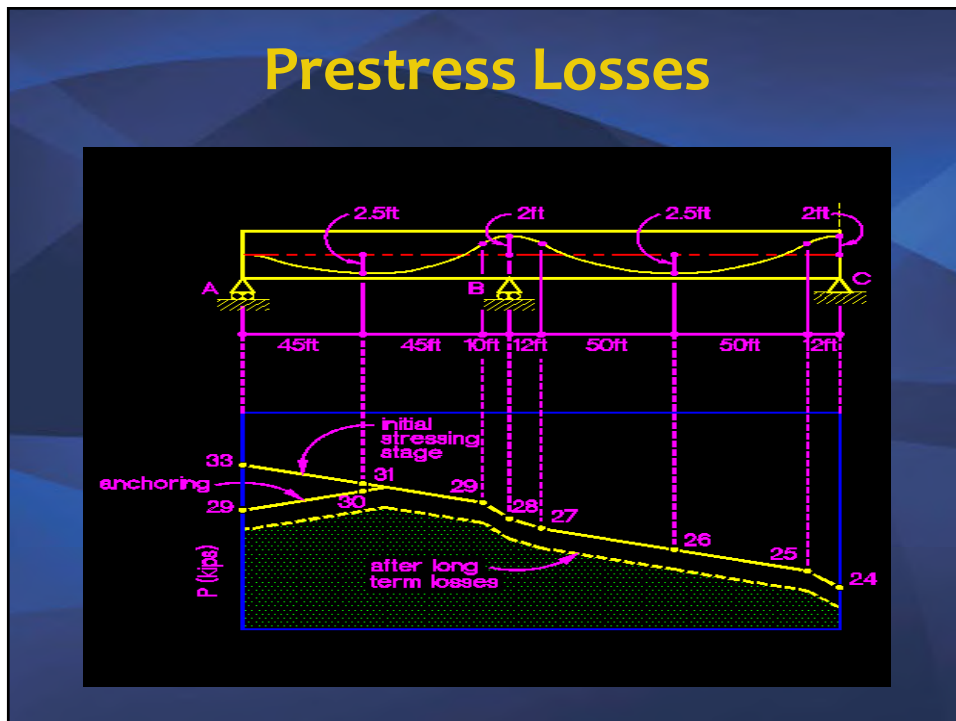

116

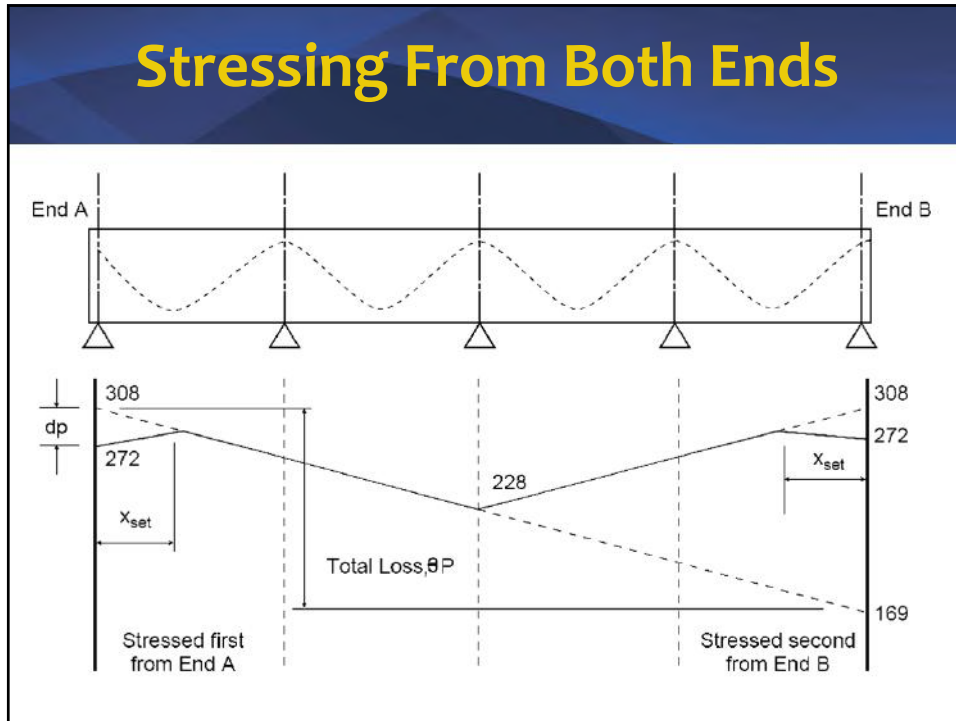

117

TENDON ELONGATION

- Use the following formula to calculate the elongation of a tendon:

$$\Delta = \frac{F_{AVG} \times L}{A \times E}$$

F_{AVG} = Prestress force in Kips (Average Force After Friction; (approximately at 70% MUTS)
 L = Length of the prestressing steel in inches
 A = Area of the prestressing steel in sq. in.
 E = Modulus of elasticity of the prestressing steel in ksi

118

Stress in Post-Tensioning Steel for Service Load Design

- Initial prestress: $f_{pi} = f_{pj} - ES - F - A$
- Effective prestress: $f_{pe} = f_{pi} - C - S - R$

Where:

- f_{pi} = Initial stress in post-tensioning strands
- f_{pj} = Jacking stress in post-tensioning strands
- f_{pe} = Effective stress in post-tensioning strands after all losses

Final Effective Force: Force in tendon after all initial and long term losses.

119

Final Effective Force

- Final Effective **Force** in the prestressing steel is calculated by taking into account all *Immediate* and *Long Term Losses*.
- This **force** is typically calculated by the post-tensioning supplier.
- F_e can be approximated to be 65% of Breaking Load

For ½” grade 270 steel:
 $270 \text{ ksi} \times 0.153 \text{ in}^2 \times 0.65 = 26.8 \text{ Kips}$

120

STEP 1 – PRELIMINARY DESIGN

- Determine structural system (one-way or two-way)
- Coordinate slab spans/column layout with architect
 - Determine slab thickness
 - Note: LL/DL ratio must be < 1.0 to use Table 2.1 of PTI’s “Design of Post-Tensioned Slabs With Unbonded Tendons” publication
- Establish consistent sign convention for gravity loads and primary moment, P_e

121

Preliminary Design Span/Depth Ratio

Floor System	Span/Depth Ratio*
One-way slabs	48
Two-way slabs	45
Two-way slab with drop panel (minimum drop panel L/6 each way)	50
Two-way slab with two-way beams	55
Two-way waffle slab (5 ft x 5 ft grid) (1.5 x 1.5 m)	35
Beams ($b \approx h/3$)	20
Beams ($b \approx 3h$)	30
One-way joists	40

Source:
Design of Post-Tensioned Slabs With Unbonded Tendons; 3rd Ed., PTI

*These values apply for members with LL/DL ratios < 1.0

122

Minimum Slab Thickness

(Governed by Fire Rating, IBC 2015, Table 722.2.1.1)

Slab Thickness for Fire Endurance [in. (mm)]				
Aggregate Type	4 hr	3 hr	2 hr	1 hr
Siliceous	7.0 (180)	6.2 (155)	5.0 (125)	3.5 (90)
Carbonate	6.6 (170)	5.7 (145)	4.6 (115)	3.2 (80)
Sand Ltwt Conc.	5.4 (135)	4.6 (115)	3.8 (95)	2.7 (70)
Ltwt Concrete	5.1 (130)	4.4 (110)	3.6 (90)	2.5 (65)

123

Establish Tendon Profile

Post-Tensioned Reinforcement

- Most buildings are constructed with unbonded tendons
- Use parabolic tendon profile for uniformly loaded beams
- Determine Cover
 - Fire Rating Criteria
 - Durability Considerations

124

Concrete Cover

(Governed by Fire Rating; IBC 2015)

Cover Thickness for Fire Endurance – Carbonate and sand-lightweight aggregate concrete - in. (mm)					
Restrained / Unrestrained	Structure Type	4 hr	3 hr	2 hr	1 hr
Restrained	Solid Slabs	1 ¼ (32)	1 (25)	¾ (19)	-
	Beams & Girders 8" Wide	2 ½ (63)	2 (51)	1 ¾ (44)	-
	Beams & Girders > 12" Wide	2 (51)	1 ¾ (44)	1 ½ (38)	-
Unrestrained	Solid Slabs	-	2 (51)	1 ½ (38)	-
	Beams & Girders 8" Wide		4 ½ (114)	2 ½ (63)	1 ¾ (44)
	Beams & Girders > 12" Wide	3 (76)	2 ½ (63)	2 (51)	1 ½ (38)

125

Restrained vs. Unrestrained

- A span is considered to be restrained when it can resist the horizontal forces developed during a fire
- Typically end bays are considered to be unrestrained unless calculations can show otherwise (ACI 423.3-05)
- Different interpretation of Code: Cast-in-place concrete slab could be considered restrained

126

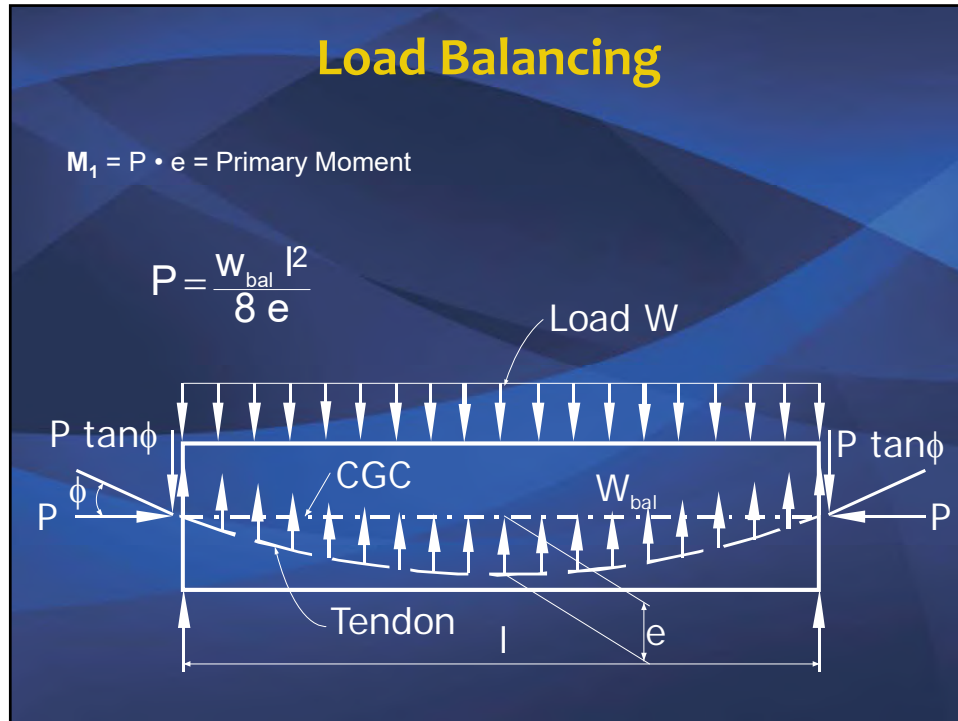

127

Preliminary Design of PT

- Determine Minimum Prestressing
 - One way Slabs/Parking Garages
 - Aggressive environments use 150-200 psi (1.0-1.4 MPa)
 - Normal environment use 125 psi (0.9 MPa)
 - Temperature tendons use 100 psi (0.7 MPa)
 - Two Way Slabs
 - Minimum use 125 psi (0.9 MPa)
- Load Balancing:
 - 60% to 70% of DL for one- and two-way slabs
 - 70% to 80% of DL for beams
 - 100% for spandrel beams supporting ext. cladding

128

Variations to Estimations

- End bays may require more PT for the same span
- Heavy exterior skin loads that must be supported by the slab
- Parking slab PT quantity will increase due to increased clear cover requirements in aggressive regions

129

STEP 2 – DETERMINE LOADING

- Dead Loads [from preliminary section thickness]
- Live Loads [IBC: 40 psf (1.9 kN/m²) for parking]
- Lateral Loads [e.g., wind, seismic, etc.]

130

STEP 3 – CALCULATE SECTION PROPERTIES

- Slab section properties
- Column properties
- Drop panel properties for two-way slabs; dimensions per Sec. 8.2.4 apply to nonprestressed slabs only

131

STEP 4 – MATERIAL PROPERTIES

- Slab concrete properties f'_c
 - Typically use 5,000 psi (35 MPa) concrete
- Column concrete properties f'_c
 - Typically use 5,000 psi (35 MPa) concrete
- Non-prestressed reinforcement properties f_y
 - Typically 60 ksi (0.4 MPa) steel
- Post-tensioning reinforcement properties f_{pu}
 - Typically 270 ksi (1860 MPa) steel

132

STEP 5 – SET DESIGN PARAMETERS

- Set allowable stresses (initial and final)
- Set average compression limits
- Set target balanced loading (65% to 85% total DL)
- Set cover requirements for reinforcement
- PT tendons : drape profile, center of gravity
- Set load combinations

133

Serviceability Requirements

- ACI 318-19, Sec. 24.5.2.1

Table R24.5.2.1—Serviceability design requirements

	Prestressed			Nonprestressed
	Class U	Class T	Class C	
Assumed behavior	Uncracked	Transition between uncracked and cracked	Cracked	Cracked
Section properties for stress calculation at service loads	Gross section 24.5.2.2	Gross section 24.5.2.2	Cracked section 24.5.2.3	No requirement
Allowable stress at transfer	24.5.3	24.5.3	24.5.3	No requirement
Allowable compressive stress based on uncracked section properties	24.5.4	24.5.4	No requirement	No requirement
Tensile stress at service loads 24.5.2.1	$\leq 7.5\sqrt{f'_c}$ *	$7.5\sqrt{f'_c} < f_t \leq 12\sqrt{f'_c}$ **	No requirement	No requirement
Deflection calculation basis	24.2.3.8, 24.2.4.2 Gross section	24.2.3.9, 24.2.4.2 Cracked section, bilinear	24.2.3.9, 24.2.4.2 Cracked section, bilinear	24.2.3, 24.2.4.1 Effective moment of inertia
Crack control	No requirement	No requirement	24.3	24.3
Computation of Δf_{ps} or f_t for crack control	—	—	Cracked section analysis	$M/(A_s \times \text{lever arm})$, or $2/3f_p$
Side skin reinforcement	No requirement	No requirement	9.7.2.3	9.7.2.3

* ($\leq 0.625\sqrt{f'_c}$ metric)

** ($0.625\sqrt{f'_c} < f_t \leq \sqrt{f'_c}$ metric)

134

Allowable Stresses: ACI 318-19

Stress at Extreme Fiber in Tension, f_t :

- Class U: $f_t \leq 7.5\sqrt{f'_c}$ ($f_t \leq 0.625\sqrt{f'_c}$ in MPa)
 - One-way – $f_t \leq 7.5\sqrt{f'_c}$ ($0.625\sqrt{f'_c}$ in MPa)
 - Two-way slabs – $f_t \leq 6\sqrt{f'_c}$ ($0.5\sqrt{f'_c}$ in MPa)
 - Uncracked: Gross cross section properties

- Class T: $7.5\sqrt{f'_c} < f_t \leq 12\sqrt{f'_c}$ ($0.625\sqrt{f'_c} < f_t \leq 0.5\sqrt{f'_c}$ in MPa)
 - Beams and one-way slabs only
 - Transition: Gross cross section properties

- Class C: $f_t > 12\sqrt{f'_c}$ ($f_t > 0.5\sqrt{f'_c}$ in MPa)
 - Cracked: Cracked section properties

135

STEP 6 – ANALYSIS

- Calculate post-tensioning force, P, as maximum of:
 - P due to balanced load
 - P per allowable average compression
- Calculate member moments due to gravity loads
- Compute moments due to PT equivalent loads and calculate secondary moments ($M_2 = M_{bal} - P_e$)
- Modify tendon drape or force P as required to achieve the targeted balanced load

136

STEP 7 – DESIGN

- Check service load stresses due to $M_{unbal} + P$
- Calculate min. amount of non-prestressed reinforcement
- Calculate temperature and shrinkage reinforcement
- Check ultimate strength & supplement with non-prestressed reinforcement, if required
- Check punching shear and deflection limitations

137

STEP 8 – FINAL CHECKS

- Finalize tendon and reinforcement layout
- Check allowable stresses at:
 - Transfer
 - Service load
 - Extreme top and bottom fibers using the **final** PT forces (or number of tendons selected)

138

Serviceability Requirements

- Just after Transfer
 - (a) Extreme fiber stress in compression – $0.6 f'_{ci}$
 - (b) Extreme fiber stress in tension except as permitted in (c) – $3\sqrt{f'_{ci}}$
 - (c) Extreme fiber stress in tension at ends of simply supported members – $6\sqrt{f'_{ci}}$
- At Service Loads
 - (a) Extreme fiber stress in compression due to prestress plus sustained load – $0.45 f'_c$
 - (b) Extreme fiber stress in compression due to prestress plus total load – $0.6 f'_c$

139

PRELIMINARY DESIGN TABLES

PTI DC20.9-11: Guide for Design of Post-Tensioned Buildings

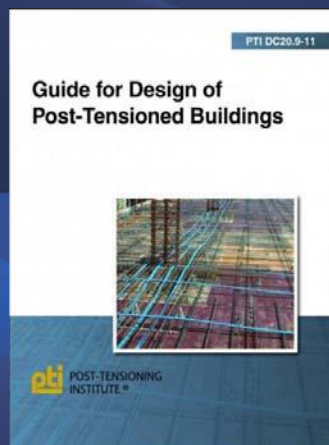

Includes:

- *Chapter 2:* PT floor systems
- *Chapter 3:* One-way systems
- *Chapter 4:* Two-way systems
- *Chapter 5:* Vertical elements (RTS) and lateral load consideration
- *Chapter 6:* Preliminary design tables
- *Chapter 7:* Design and construction details; construction procedures
- *Chapter 8:* Structural observation and field personnel certification

140

PTI DC20.9-11 Feature - Design Tables

- Intent of the tables
 - Easy-to-use tools for architects, contractors
 - Starting point for structural design for engineers
- Provide preliminary estimates for Unbonded PT Slabs subject to gravity loads:
 - Member sizes
 - Post tensioning material quantities (lb/ft²)
 - Nonprestressed reinforcement material quantities (lb/ft²)

141

Design Basis for Tables

- Gravity loads analysis meeting ACI 318-08 & IBC 2006 with optimal sizes and quantities
 - Post-Tensioning Quantities based on:
 - Min. F/A requirement (non-aggressive environment)
 - Serviceability: stresses and deflection
 - Min. Load Balancing provided = 50% (SW+SDL)
 - Non-Prestressed Reinforcement:
 - Strength
 - Min. Bonded Reinforcement (ACI Code: one-way slab)

142

Slab Types Covered

Building Use

Parking

Office

Residential

Podium

One-Way

Narrow Beam + Slab System

A. Beams + Joist
B. Wide Beam + Slab System

--

--

Two-Way

Flat Slab with No Drops

Typical Loading, Several Spans and Member Size Combinations

143

Table 6.2—Preliminary design table for one-way parking structures (beam and slab system)

Basic design parameters and assumptions:

- Loading: DL = Self Weight + 5 psf (SDL)
- LL = 40 psf
- Slab and beam minimum $F/A = 125$ psi (0.9 MPa)
- Shrinkage and temperature minimum $F/A = 100$ psi (0.7 MPa) based on ACI 318-08
- Concrete: $f_c = 5000$ psi (34.5 MPa), $f_r = 3000$ psi (20.7 MPa)
- Ass (12) kips
- Temp. 1.5 in. (38 mm) top, 1.0 in. (25.4 mm) bottom-interior span, 1.75 in. (44.5 mm) bottom-exterior span
- Cover to nonprestressed reinforcement: Beams 2.0 in. (51 mm) top and bottom, Slab 1.25 in. (31.75 mm) top and 0.75 in. (19 mm) bottom
- Column size: 24 x 24 in. (610 x 610 mm)

Design Parameters

Book
Extract
of Design
Tables

Bay width (X-dir), ft	Beam span configuration (ly1, ly2, ly3), ft	Slabs				Beams				TOTAL		
		Size, in.	Span to depth ratio	Material required		Size, in.	Span to depth ratio	Material required		Temp. Tend.	Material Required	
				PT, psf	Rebar, psf			PT, psf	Rebar, psf		PT, psf	Rebar, psf
18	58, 58, 58	5	43.2	0.218	0.450	16x32	21.8	0.290	0.827	0.09	0.60	1.28
	16x34					21.2	0.290	0.827	0.09	0.60	1.28	
	16x36					20.7	0.290	0.827	0.09	0.60	1.28	
20	58, 58, 58	5	5	0.218	0.450	16x32	21.8	0.290	0.827	0.09	0.60	1.28
	16x34					21.2	0.290	0.827	0.09	0.60	1.28	
	16x36					20.7	0.290	0.827	0.09	0.60	1.28	
24	58, 58, 58	6	6	0.218	0.450	16x32	21.8	0.290	0.827	0.09	0.60	1.28
	16x34					21.2	0.290	0.827	0.09	0.60	1.28	
	16x36					20.7	0.290	0.827	0.09	0.60	1.28	
27	58, 58, 58	7	7	0.218	0.450	16x32	21.8	0.290	0.827	0.09	0.60	1.28
	16x34					21.2	0.290	0.827	0.09	0.60	1.28	
	16x36					20.7	0.290	0.827	0.09	0.60	1.28	
30	58, 58, 58	7.5	8	0.218	0.450	16x32	21.8	0.290	0.827	0.09	0.60	1.28
	16x34					21.2	0.290	0.827	0.09	0.60	1.28	
	16x36					20.7	0.290	0.827	0.09	0.60	1.28	

Member sizes
PT Quantity
Rebar Quantity

144

Parking Example – Extract from Guide

Table 6.2—Preliminary design table for one-way parking structures (beam and slab system)

Design Parameters

- Basic design parameters and assumptions:
- Loading: DL = Self Weight + 5 psf (SDL)
LL = 40 psf
 - Slab and beam minimum F/A = 125 psi (0.9 MPa)
 - Shrinkage and temperature minimum F/A = 100 psi (0.7 MPa) based on ACI 318-08
 - Concrete: $f'_c = 5000$ psi (34.5 MPa), $f'_{ci} = 3000$ psi (20.7 MPa)
 - Assumed final effective force per 1/2" strand tendon = 27 kips (120 kN)
 - Tendon CGS: Beams 3 in. (76 mm) top and bottom, Slab 1.5 (38 mm) top, 1.0 in. (25.4 mm) bottom-interior span, 1.75 in. (44.5 mm) bottom-exterior span
 - Cover to nonprestressed reinforcement: Beams 2.0 in. (51 mm) top and bottom, Slab 1.25 in. (31.75 mm) top and 0.75 in. (19 mm) bottom
 - Column size: 24 x 24 in. (610 x 610 mm)

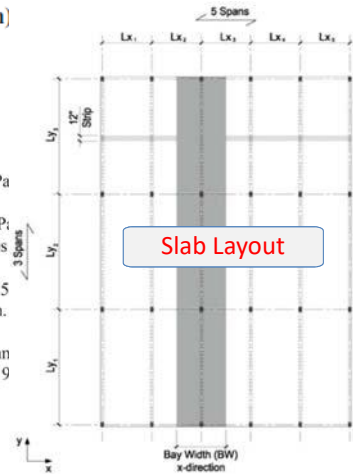

145

Parking Example – Table Quantities

Table 6.2—Preliminary design table for one-way parking structures (beam and slab system)

Bay width (X-dir), ft	Beam span configuration (Ly1, Ly2, Ly3), ft	Slabs				Beams				Temp Tend., psf	TOTAL Material Required	
		Size, in.	Span to depth ratio	Material required		Size, in.	Span to depth ratio	Material required			PT, psf	Rebar, psf
				PT, psf	Rebar, psf			PT, psf	Rebar, psf			
18	58, 58, 58	5	43.2	0.218	0.450	16x32	21.8	0.290	0.827	0.09	0.60	1.28
	60, 60, 60					16x34	21.2	0.290	0.827	0.09	0.60	1.28
	62, 62, 62					16x36	20.7	0.290	0.827	0.09	0.60	1.28
20	58, 58, 58	5	48	0.249	0.425	16x32	21.8	0.288	0.746	0.081	0.62	1.18
	60, 60, 60					16x34	21.2	0.288	0.747	0.081	0.62	1.18
	62, 62, 62					16x36	20.7	0.288	0.747	0.081	0.62	1.18
24	58, 58, 58	6	48	0.277	0.543	18x32	21.8	0.345	0.732	0.09	0.72	1.28
	60, 60, 60					18x34	21.2	0.345	0.733	0.09	0.72	1.28
	62, 62, 62					18x36	20.7	0.345	0.735	0.09	0.72	1.28
27	58, 58, 58	7	46.3	0.327	0.629	20x32	21.8	0.373	0.737	0.10	0.80	1.37
	60, 60, 60					20x34	21.2	0.373	0.732	0.10	0.80	1.37
	62, 62, 62					20x36	20.7	0.373	0.738	0.10	0.80	1.37
30	58, 58, 58	7.5	48	0.358	0.691	24x32	21.8	0.402	0.781	0.108	0.87	1.48
	60, 60, 60					24x34	21.2	0.402	0.777	0.108	0.87	1.48
	62, 62, 62					24x36	20.7	0.402	0.781	0.108	0.87	1.48

146

Parking Example – Table Quantities

Bay width (X-dir), ft	Beam span configuration (Ly1, Ly2, Ly3), ft	Slabs				Beams				Temp Tend., psf	TOTAL			
		Size, in.	Span to depth ratio	Material required		Size, in.	Span to depth ratio	Material required			Material Required			
				PT, psf	Rebar, psf			PT, psf	Rebar, psf		PT, psf	Rebar, psf		
	58, 58, 58	↓				16x32	21.8	0.290	0.827	0.09	↓	0.60	↓	1.28
18	60, 60, 60	5	43.2	0.218	0.450	16x34	21.2	0.290	0.827	0.09		0.60		1.28
	62, 62, 62					16x36	20.7	0.290	0.827	0.09		0.60		1.28

- Lx = 18 ft (bay width)
- Ly = 60 ft (Beam Span →)

Gravity Design Only – Optimal Solution

Member sizes

- Slab = 5 in.
- Beams = 16 x 34 in.

Material from Table

PT = 0.60 lb/ft²
Rebar = 1.28 lb/ft²

147

Other Considerations to Be Added

- Aggressive environment
- Seismic or wind consideration
- Geometry changes , special loading
- Non–prestressed reinforcement for detailing
- Punching shear

148

Parking Example – Total Quantities

Items	Post Tensioning lb/ft ²	Non-Prestressed Reinforcement lb/ft ²
Gravity Loads	0.60	1.28
Should precompression be increased from 125psi	N/A	-
Should load balancing be increased from 50%	N/A	-
Exterior edge loads	0.03 (assumed)	0.1 (assumed)
Transverse beams	0.04 (assumed)	0.2 (assumed)
Transfer girders	N/A	N/A
Lateral load	-	N/A
Bottom mesh	-	N/A
Backup and support steel	-	0.4 (assumed)
Misc. Steel (trim and openings)	-	0.2 (assumed)
Pour strips	-	0.3 (assumed)
Restraint	-	N/A
Punching shear	N/A	N/A
Total	0.67	2.48

149

SHORTENING RESTRAINT

Reasons & Mitigation

- Building shape
- Restraining elements
- Detailing

150

Slab Shortening Components

Category	% Of Total
Elastic	7 %
Creep	9 %
Shrinkage	56%
Temperature	28%
Total	100.0%

- What is the PT contribution?
- What causes the largest part of shortening?

151

Shortening

PT Manual:

6.2.3.4 Expansion Joint and Closure Strip Spacing Guidelines

The following general limitations on the lengths between closure strips and expansion joints are recommended, unless other details or methods are specified to mitigate cracking caused by restraint to shortening:

- If the slab length is less than 250 feet, no closure strip or expansion joint is necessary.
- For slab lengths between 250-325 feet, provide one centrally located closure strip.
- If the slab length is between 325 and 400 feet, consider using two closure strips open for at least 60 days.
- For slabs greater than 400 feet an expansion joint is recommended.

152

Closure Strip

- CS's reduce creep and shrinkage effects
- CS's remain open until creep and shrinkage has taken place
- 3 to 4 ft wide
- Open for how long?
- Also called delay strip



153

Creep & Shrinkage vs. Time

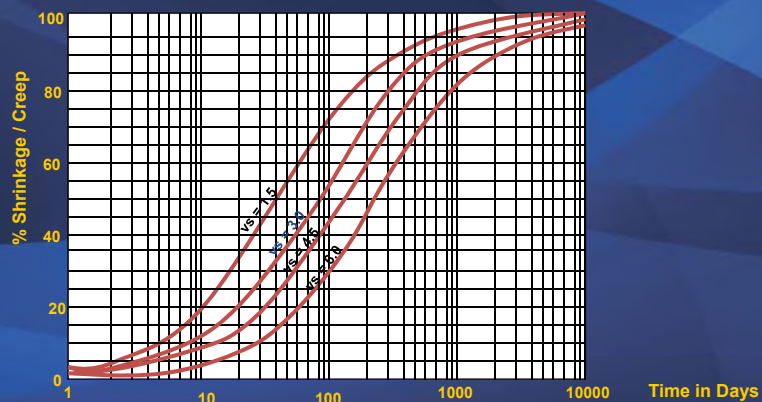

154

Arrangement of Shear Walls

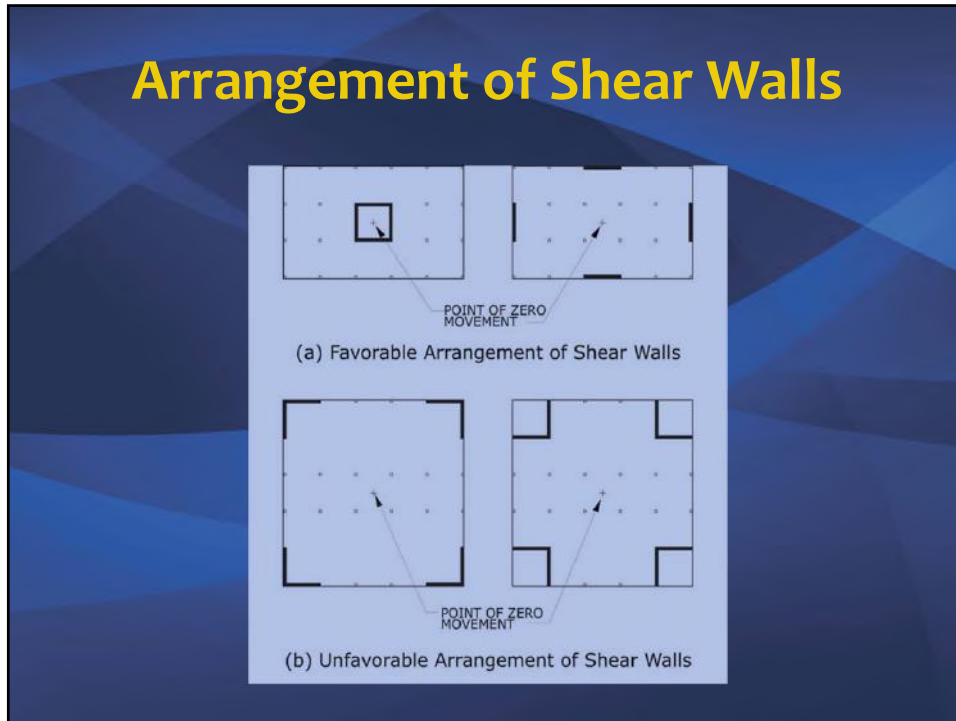

155

Movement Joints

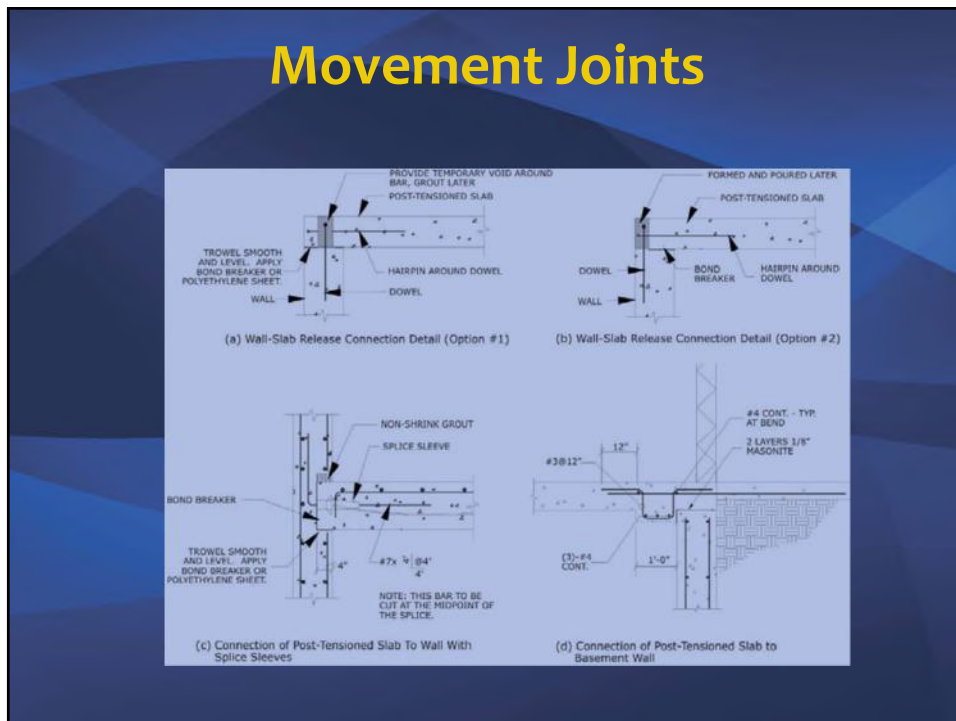

156

DESIGN & CONSTRUCTABILITY **ISSUES**

- Code Requirements Changes
- Common Design Issues
- Construction Issues

157

FACTS VS. MYTHS

Facts About PT

- PT concrete is not crack free
- PT concrete is not water proof
- You can drill / make openings in PT slab
- If you drill into a tendon, it will not fly out of the building
- It is possible to upgrade / repair a PT structure
- PT structures are durable

158

Code Provisions

- ACI 318-11
Chapter 18 – Prestressed Concrete
- ACI 318-14 (Member based)
Prestressed concrete provisions within all chapters
- ACI 318-19
Additional changes

159

Code Provisions

3.2—Referenced standards

423.7-14—Specification for Unbonded Single-Strand Tendon Materials

ACI 423.7 requires the use of encapsulated tendon systems for applications subject to this Code.

160

Encapsulation

Encapsulated anchorage

- Prevent water infiltration and corrosion
- Steel casting coated with corrosion protection
- Lockable encapsulation sleeves
- Lockable encapsulation cap



161

Shrinkage and Temperature Tendons

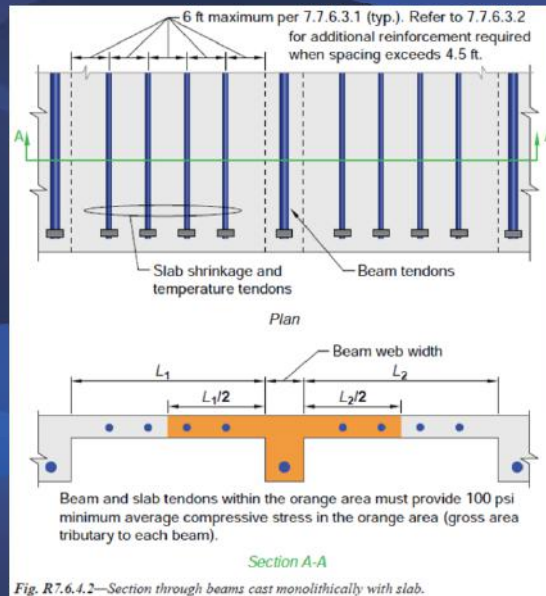

162

Shrinkage and Temperature Tendons

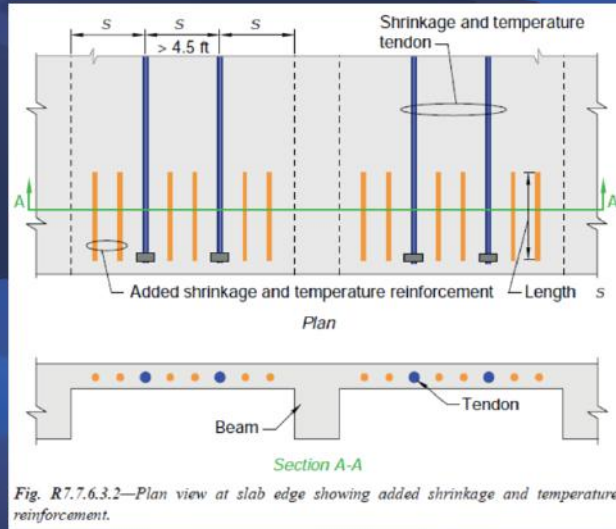

Fig. R7.7.6.3.2—Plan view at slab edge showing added shrinkage and temperature reinforcement.

163

Minimum Nonprestressed Reinforcement

7.6.2.1 For slabs with bonded prestressed reinforcement, total quantity of A_s and A_{ps} shall be adequate to develop a factored load at least 1.2 times the cracking load calculated on the basis of f_r as given in 19.2.3.

7.6.2.3 For slabs with unbonded tendons, the minimum area of bonded deformed longitudinal reinforcement, $A_{s,min}$, shall be:

$$A_{s,min} \geq 0.004A_{ct} \quad (7.6.2.3)$$

where A_{ct} is the area of that part of the cross section between the flexural tension face and the centroid of the gross section.

164

Common Design Issues

Structural modeling

- DO NOT use simplified analysis using coefficients (Direct Design Method)
- Use the Equivalent Frame Method, EFM
Sec. 8.11 of ACI 318-14, excluding Sec. 8.11.6.5 and 8.11.6.6. No longer in ACI 318-19 but permitted per Sec. 8.2.1
- DO NOT use middle/column strip concept
- Apply total moment to entire bay section when using EFM

165

Common Design Issues

Incomplete design

Specify all PT requirements:

- **Final effective force**, or the number of tendons and corresponding final effective force
- **Tendon profile**

166

Serviceability Requirements

- ACI 318-19, Sec. 24.5.2.1
- Not checking initial stress conditions

Table R24.5.2.1—Serviceability design requirements

	Prestressed			Nonprestressed
	Class U	Class T	Class C	
Assumed behavior	Uncracked	Transition between uncracked and cracked	Cracked	Cracked
Section properties for stress calculation at service loads	Gross section 24.5.2.2	Gross section 24.5.2.2	Cracked section 24.5.2.3	No requirement
Allowable stress at transfer	24.5.3	24.5.3	24.5.3	No requirement
Allowable compressive stress based on uncracked section properties	24.5.4	24.5.4	No requirement	No requirement
Tensile stress at service loads 24.5.2.1	$\leq 7.5\sqrt{f'_c}$ *	$7.5\sqrt{f'_c} < f_t \leq 12\sqrt{f'_c}$ **	No requirement	No requirement
Deflection calculation basis	24.2.3.8, 24.2.4.2 Gross section	24.2.3.9, 24.2.4.2 Cracked section, bilinear	24.2.3.9, 24.2.4.2 Cracked section, bilinear	24.2.3, 24.2.4.1 Effective moment of inertia
Crack control	No requirement	No requirement	24.3	24.3
Computation of Δf_{ps} or f_t for crack control	—	—	Cracked section analysis	$M/(A_e \times \text{lever arm})$, or $2/3f_t$
Side skin reinforcement	No requirement	No requirement	9.7.2.3	9.7.2.3

* $(\leq 0.625\sqrt{f'_c} \text{ metric})$

** $(0.625\sqrt{f'_c} < f_t \leq \sqrt{f'_c} \text{ metric})$

167

Common Design Issues

Too much prestressing – using sections that are too small for the amount of force being applied

24.5.4.1 For Class U and T members, the calculated extreme concrete fiber stress in compression at service loads, after allowance for all prestress losses, shall not exceed the limits in Table 24.5.4.1.

Table 24.5.4.1—Concrete compressive stress limits at service loads

Load condition	Concrete compressive stress limits
Prestress plus sustained load	$0.45f'_c$
Prestress plus total load	$0.60f'_c$

168

Too Much PT?



169

Common Design Issues

Not coordinating space at beam/column joints for vertical column bars and PT



170

Common Design Issues

Not coordinating space at slab/column joints for congestion of rebar and PT



171

Deviations Around Openings



172

Common Design Issues

Backup bars and bursting reinforcement, ACI 318-19, Sec. 25.9.4.4.6

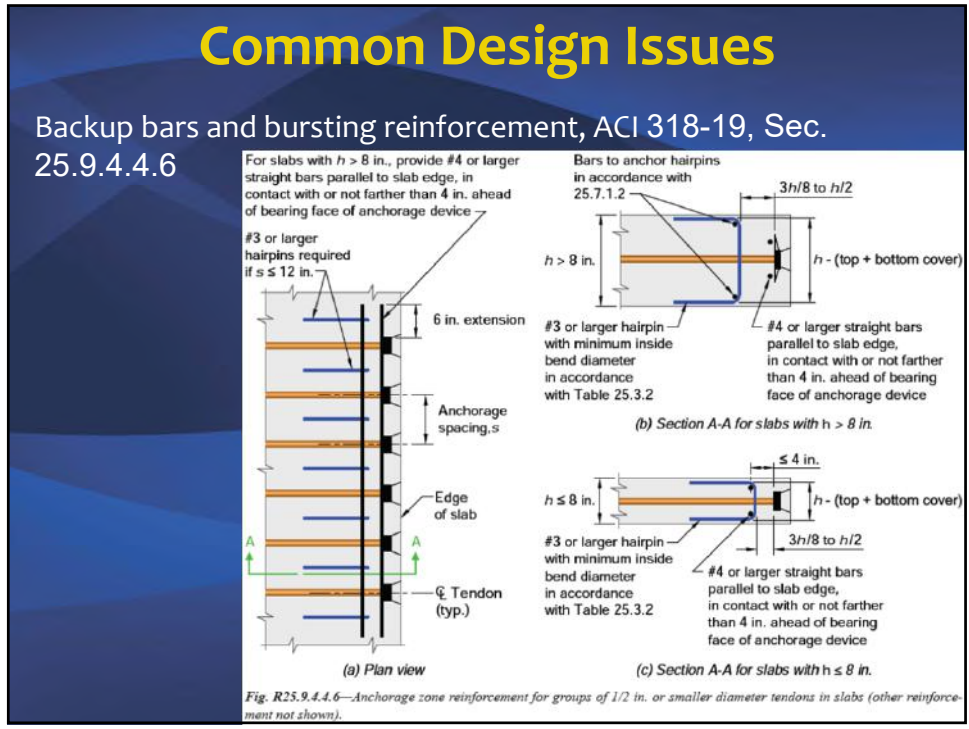

173

Backup Bars and Bursting Steel



174

Backup Bars and Bursting Steel



175



176

Common Design Issues

Requiring 2 integrity tendons through the column in a one-way slab (when supported on beams) – **This applies to 2-way slabs only**

8.7.5.6 Structural integrity

8.7.5.6.1 Except as permitted in 8.7.5.6.3, at least two tendons with 1/2 in. diameter or larger strand shall be placed in each direction at columns in accordance with (a) or (b):

(a) Tendons shall pass through the region bounded by the longitudinal reinforcement of the column.

(b) Tendons shall be anchored within the region bounded by the longitudinal reinforcement of the column, and the anchorage shall be located beyond the column centroid and away from the anchored span.

8.7.5.6.3 Slabs with tendons not satisfying 8.7.5.6.1 shall be permitted if bonded bottom deformed reinforcement is provided in each direction in accordance with 8.7.5.6.3.1 through 8.7.5.6.3.3.

8.7.5.6.3.1 Minimum bottom deformed reinforcement A_s in each direction shall be the greater of (a) and (b):

(a) $A_s = \frac{4.5\sqrt{f_c'}b_w d}{f_y}$ (8.7.5.6.3.1a)

(b) $A_s = \frac{300b_w d}{f_y}$ (8.7.5.6.3.1b)

where b_w is the width of the column face through which the reinforcement passes.

8.7.5.6.3.2 Bottom deformed reinforcement calculated in 8.7.5.6.3.1 shall pass within the region bounded by the longitudinal reinforcement of the column and shall be anchored at exterior supports.

8.7.5.6.3.3 Bottom deformed reinforcement shall be anchored to develop f_y beyond the column or shear cap face.

177

Common Design Issues

Not coordinating embed plates for curtain wall systems with the PT anchorage locations

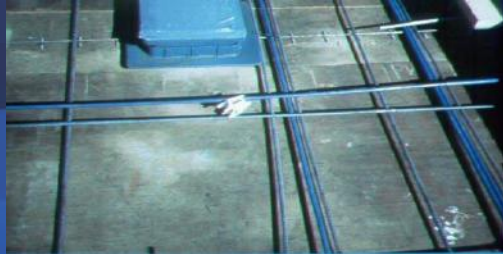

178

Common Design Issues

Specifying the same force and high/low points in spans of significantly different lengths (overbalancing in the short span):

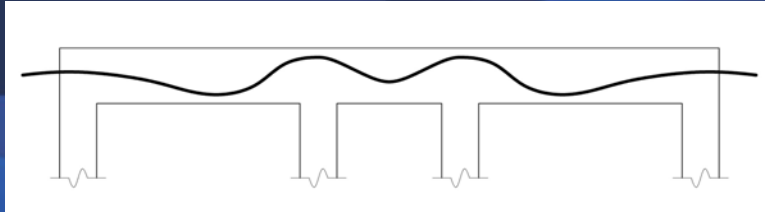

179

Common Design Issues

End bays may require more PT for the same span length

- Reduced tendon drupe
- Restrained vs. unrestrained condition
- Heavy exterior skin loads that must be supported by the slab

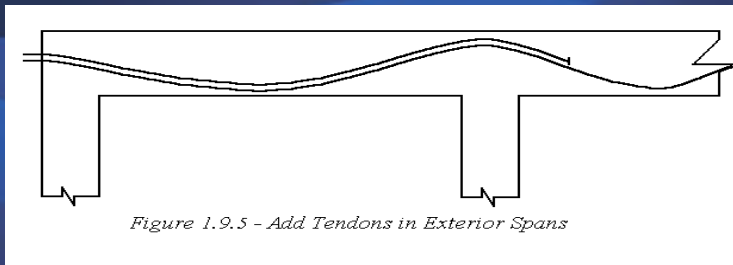

180

Common Design Issues

PROPER TENDON PLACEMENT AT CANTILEVER

181

Common Design Issues

Add tendon anchorage area reinforcement

25.9.4.4.3 For anchorage devices located away from the end of the member, bonded reinforcement shall be provided to transfer at least $0.35P_{pu}$ into the concrete section behind the anchor. Such reinforcement shall be placed symmetrically around the anchorage device and shall be fully developed both behind and ahead of the anchorage device.

P_{pu} = factored prestressing force at anchorage device, lb

182



183

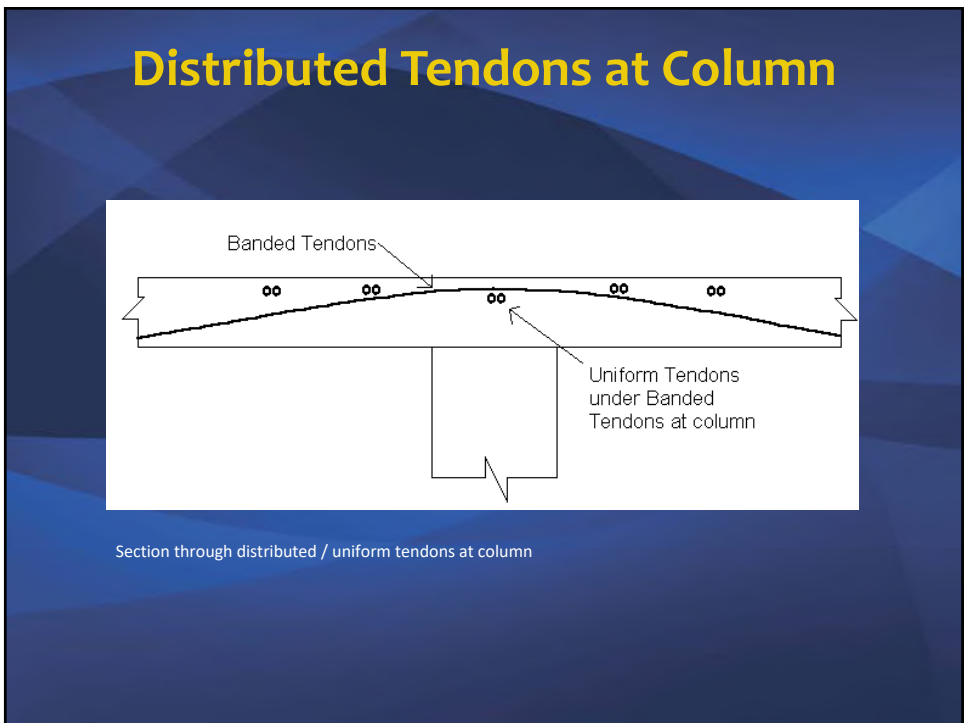

184



185

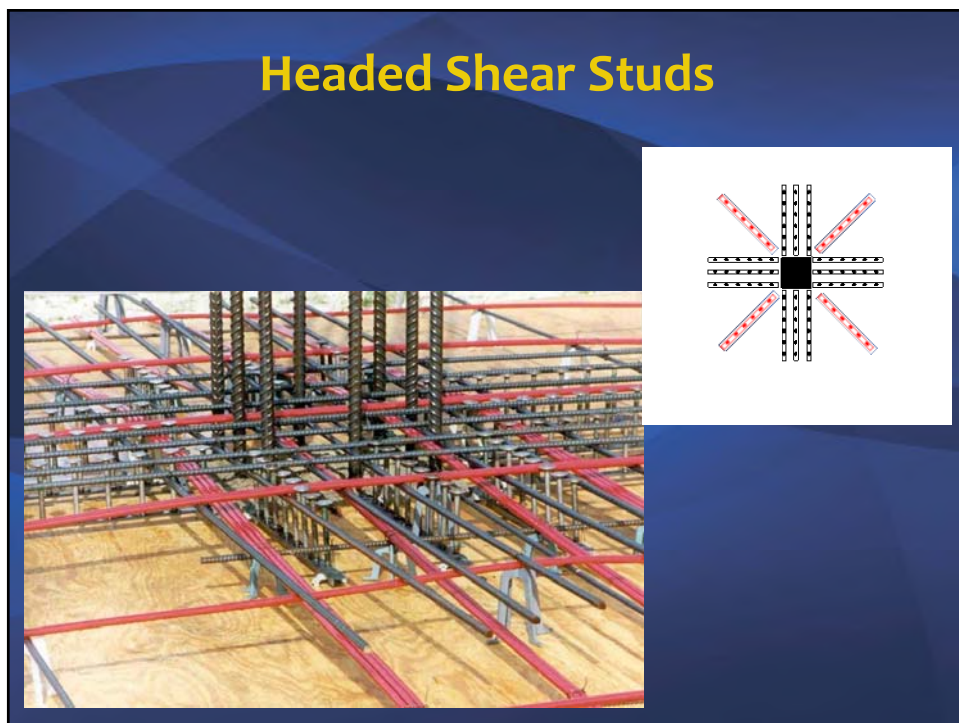

186



187

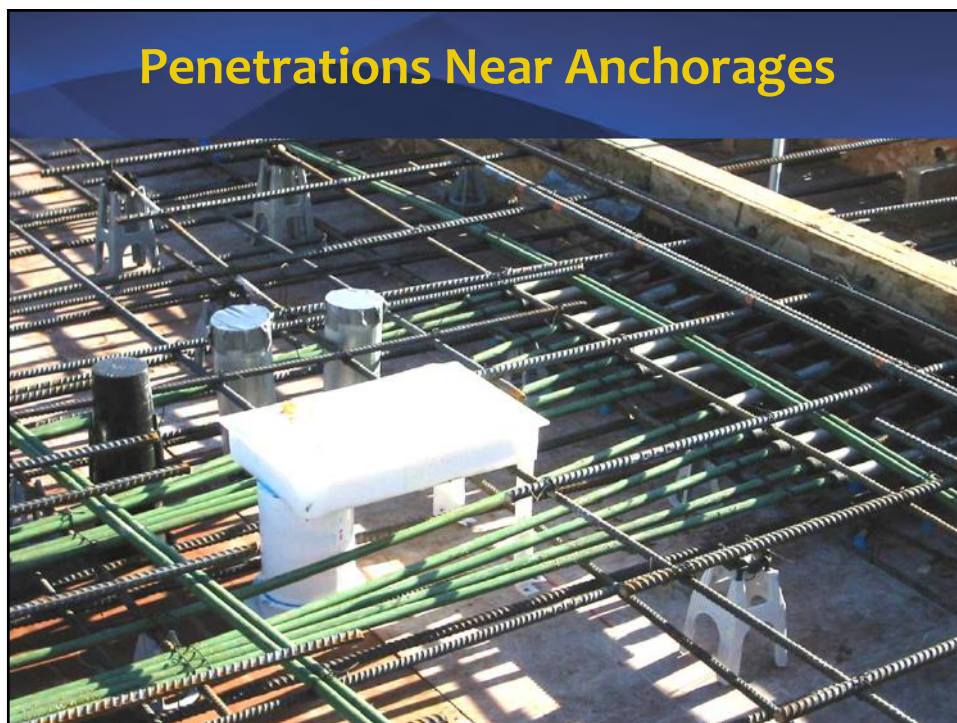

188

Penetrations in Anchor Zone

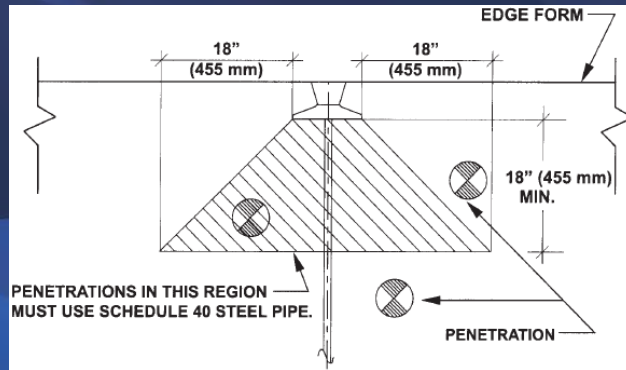

189

Conduit Too Close to Anchors

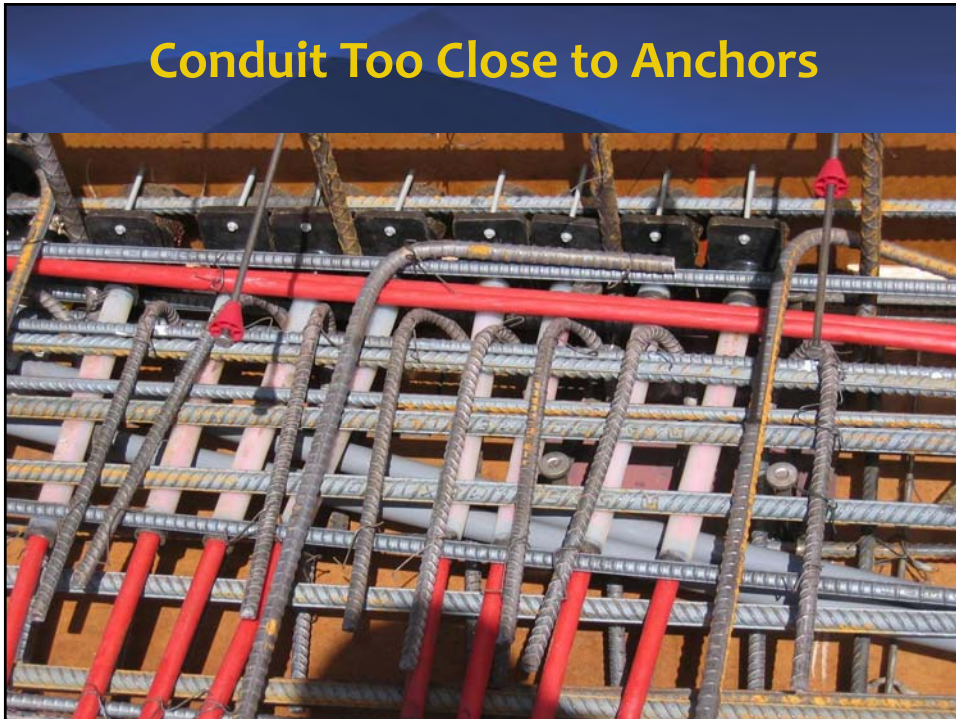

190



191

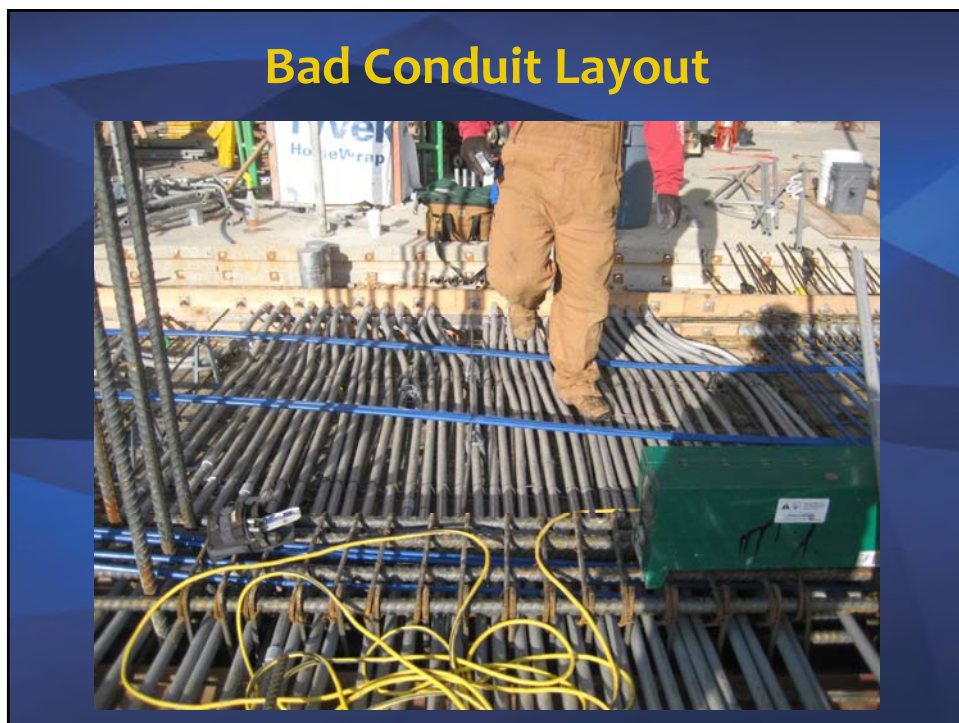

192

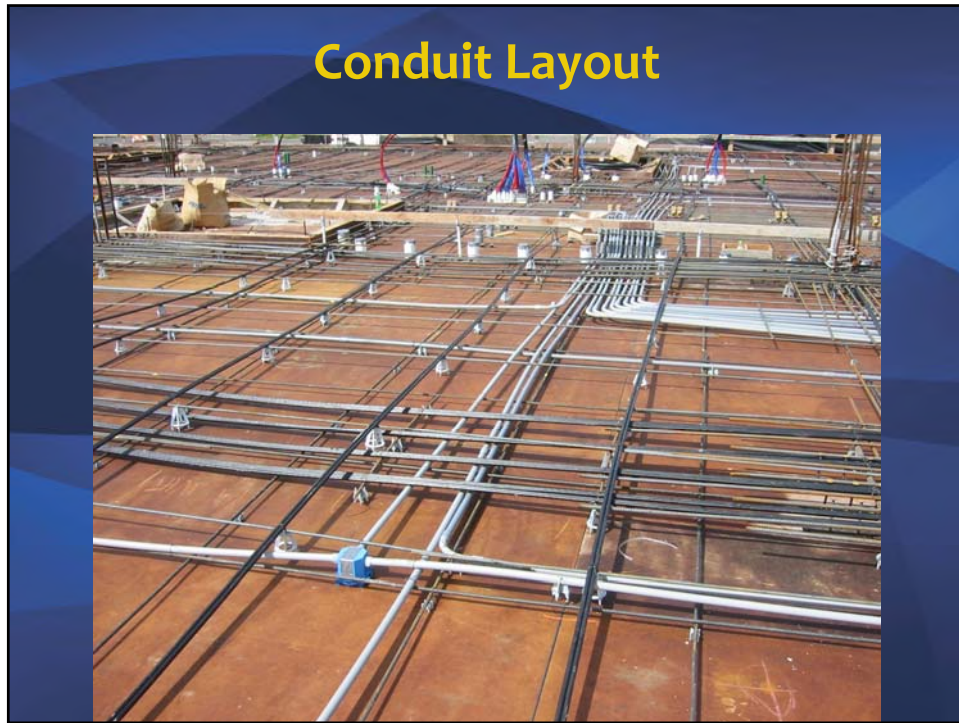

193



194



195



196

Congestion Near Supports



197

Elongation Requirements per ACI 318-19, Sec. 26.10.2

(e) Prestressing force and friction losses shall be verified by (1) and (2).

(1) Measured elongation of prestressed reinforcement compared with elongation calculated using the modulus of elasticity determined from tests or as reported by the manufacturer.

(2) Jacking force measured using calibrated equipment such as a hydraulic pressure gauge, load cell, or dynamometer.

(f) The cause of any difference in force determination between (1) and (2) of 26.10.2(e) that exceeds 5 percent for pretensioned construction or 7 percent for post-tensioned construction shall be ascertained and corrected, unless approved by the licensed design professional.

198

Elongation Requirements per ACI 318-14, Sec. 26.10.2

In practical terms

1. Use calibrated stressing equipment to stress tendons.
2. Double check prestressing force by measuring elongations and comparing them to the calculated elongations.
3. A tolerance of $\pm 7\%$ is permitted between measured and calculated elongations without further action.
4. Greater elongation difference needs to be analyzed and possible corrective actions taken as directed by LDP.

199

Elongation Discrepancy

Causes of Improper Elongation

- Poor marking procedures
- Inaccurate measurements
- Inaccurate gauge reading
- Improper stressing procedure
- Math errors
- Excessive seating loss
- Equipment malfunction

200

Analyzing Elongation Discrepancy

- Review marking and measuring procedures
- Check strand modulus of elasticity and cross sectional area
- Consider average effect of beam tendons or banded tendons
- Check for consistency
- Consider other field observations reported
- Possible corrective measures if results not acceptable:
 - Equipment (check calibration; use other set to continue stressing)
 - Restress some tendons (after a day or two)
 - Perform a lift-off on a representative tendon

201

Analyzing Elongation Discrepancy

Broken Tendons

- 2% per ACI 318

Short Tendons

- 40 ft (12.2 m) and shorter
- Consider additional elongation tolerance and lower final effective force (PTI Tech Note 16)
- Tendons should not be shorter than about 20 ft (6.1 m)

Typical Tendon Length

- Single ended pulls < ~ 120 feet
- Double ended pulls < ~ 220 feet

202

DETAILING & CONSTRUCTION **CONSIDERATIONS**

Constructability

- Can the design objective be accomplished?
 - What should the Engineer consider?
- Communication
 - Preconstruction meeting
 - Who does what?

203

Contract Documents

- **Code**
 - Adopted by Jurisdiction
 - Directed to Engineer
- **Structural Drawings**
 - Prepared by Engineer
 - Results from Design
- **Specifications**
 - Prepared by Engineer
 - Directed to Contractor
- **PT Installation Drawings**
 - Based on Contract Documents
 - Reviewed by Engineer
 - For Construction

204

How to specify PT?

Specify all PT requirements:

- **Final effective force**, or the number of tendons and corresponding final effective force
- **Tendon profile**
- Stressing sequence (transfer girders)

205

Quality of materials and workmanship...

Both critical to the performance of post-tensioning

206

PTI Certification Programs

1) Plant Certification (Process Certification)

- Unbonded Tendon Plants (Code requirement)
- PTI – ANSI accredited certification provider
- Plants
 - Unannounced inspections by independent agency
 - Certified, Provisionally Certified, Certification Suspended
 - Actions posted on PTI website

207

PTI Certification Programs

2) Field Personnel Certification Workshops

- Level 1&2 Slab-on-Ground Installer & Inspector
- Level 1 Unbonded PT Installation
- Level 1&2 Unbonded PT Installer & Inspector
- Level 1&2 Unbonded PT Repair, Rehabilitation & Strengthening
- Level 1&2 Multistrand & Grouted PT Specialist
- Level 1&2 Multistrand & Grouted PT Inspector

208

Placement Inspection Requirements

- Verify number of tendons and CGS from PT Installation and Structural drawings
- Verify that minimum number of tendons pass through column in both directions (2-way slabs)
- Look for tendons with extreme bends, horizontal sweeps, or odd configurations
- Check for damage to sheathing and encapsulation components; record the repairs
- Remove/move excessive conduit, penetrations, etc., especially by the anchors and columns
- Conduit in the slab and penetrations too close to the anchorages

209

Tendon Finishing

Filling of Stressing Pockets

- Protruding strand tail of proper length to accommodate encapsulation cap; see PT system
- Surface preparation: free from PT coating, grease, form release agent, dirt, loose concrete, etc.
- Bonding agent
- High quality premixed cementitious chloride-free low-shrinkage non metallic repair grout
- Proper mixing and application

210

BURN OFF TENDON ENDS



211

HYDRAULIC SHEAR



212

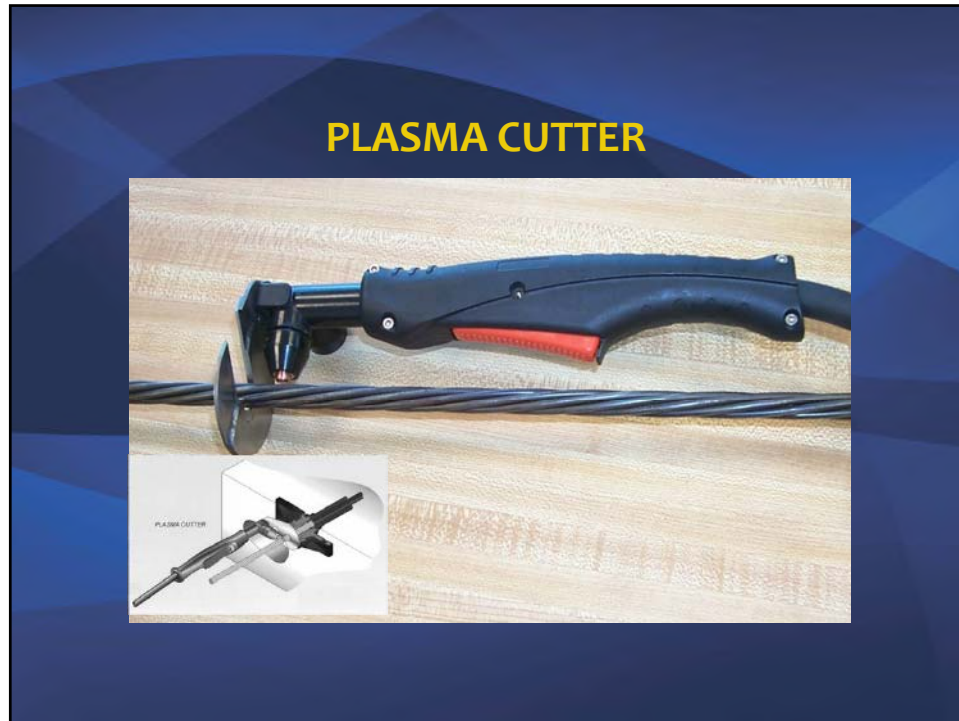

213

REPAIR, REHABILITATION, STRENGTHENING

- Corrosion
- Broken Tendons During Construction
- Repair of Existing Structures
- External Tendons

214

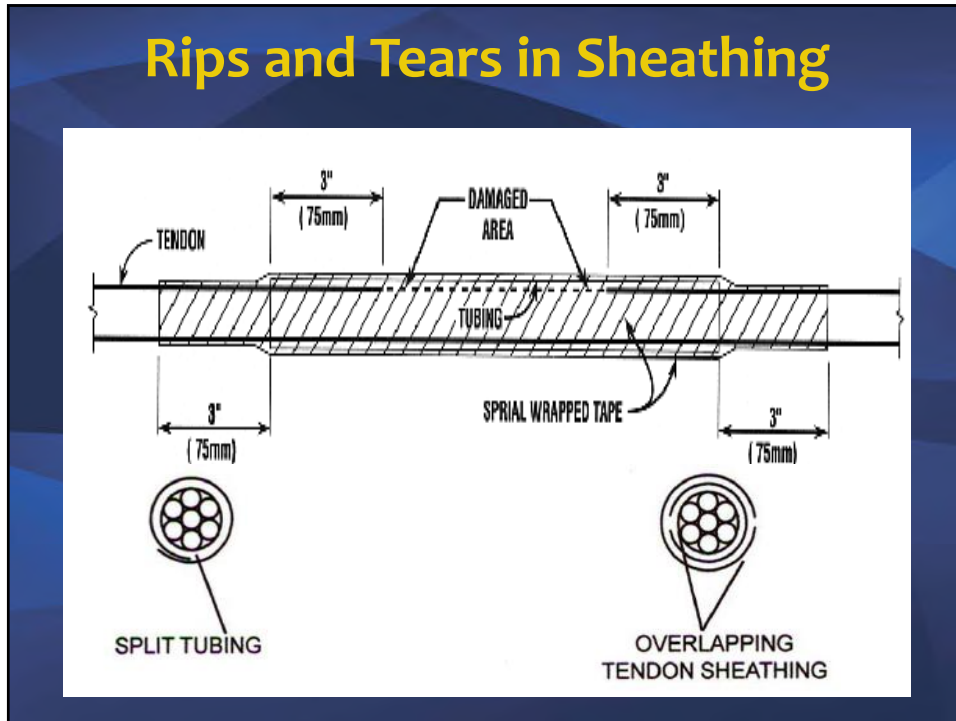

215

Rips and Tears in Sheathing

- PTI's Specification for Unbonded Single Strand Tendons states that the tape used should:
 - be self-adhesive and moisture proof
 - be non-reactive with sheathing, P-T coating, and prestressing steel
 - have elastic properties
 - have a minimum width of 2 inches
 - have a contrasting color to the tendon sheathing.

216



217



218



219



220



221



222

Reinforce Openings if Required



223

External Post-Tensioning (EPT)



224

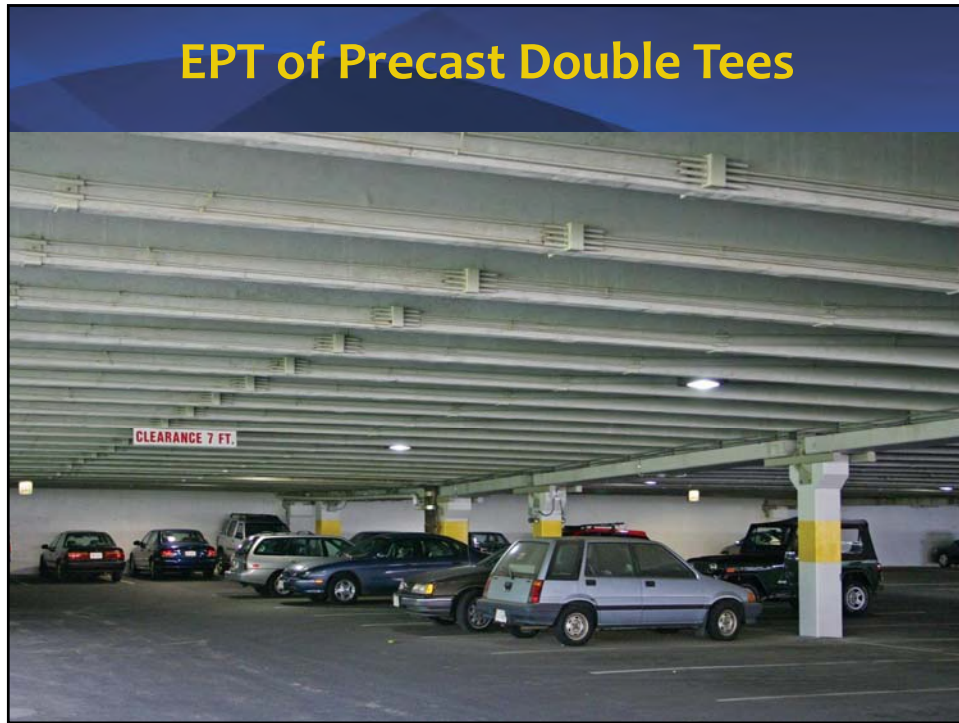

225

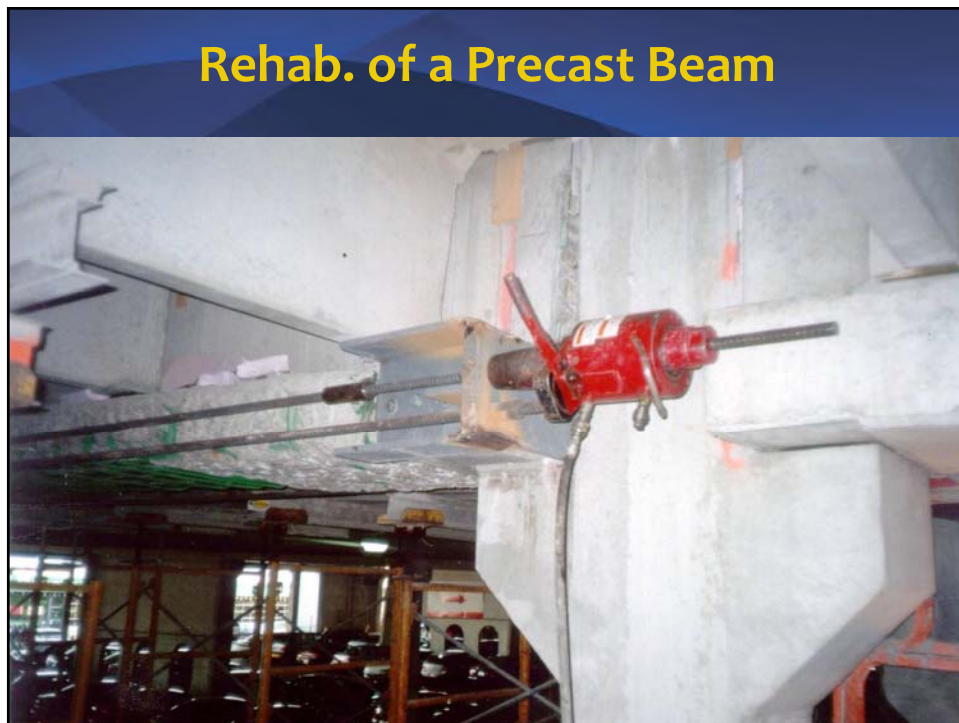

226

THANK YOU!

This Concludes the Educational Content
of This Activity

SURVEY

We welcome your feedback on this seminar.
Please complete the survey and return to the
presenter

227